



Operating Weight : 21400 kg Bucket Capacity : 0.95-1.1 m³ Engine Power : 140HP (104 kW)/ 2000 rpm

**EXCELLENT PERFORMANCE
HIGH RELIABILITY
EASE OF SERVICEABILITY**



SANY HEAVY INDUSTRY INDIA PVT. LTD.

HEAD OFFICE
Address : Plot No. E-4, Chakan Industrial Area Phase-III,
Village Kuruli, Taluka Khed, District Pune - 410501,
Maharashtra, INDIA.
E-mail : customer@care@sany.in
Website : www.sany.in
Toll Free No.: 1800-209-3337



Material & specification are subject to change without prior notice in accordance with our continuous technical innovations. Featured machines in photos may include additional equipment.

Oct 2021



SY215C-9 LC
HYDRAULIC EXCAVATOR

The C-9 series of excavators developed by SANY adopts major breakthroughs ranging from power system to control system for high efficiency and energy savings. This, in addition to insistence on 'Quality-In-Everything-We-Do', has delivered the world-class excavators best suited for the multitude of your work requirements with superior advantages of uninterrupted operations, unmatched productivity at better fuel economy, helping you make more profits.



EXCELLENT PERFORMANCE

SY215C-9 LC excavator is built with well-renowned Cummins engine and superior synchronization with advanced hydraulic system offering best balance of performance demands and fuel economy to suit job requirements and application.



HIGH RELIABILITY

Sany design and manufacturing capabilities has resulted into durability with improved life of components and longer service life. HD track chain option for higher track chain life in heavy duty terrains



BEST IN CLASS OPERATOR COMFORT

The machine is featured with comfortable seating arrangement, optimized cabin space, wider visibility, safety grills and easy access to switches. Overall, the new cabin provides comfortable and safe environment for the operator. SY215C-9 LC comes with long crawler under carriage, which provide enhanced working stability in tough underfoot condition



EASE OF SERVICEABILITY

With superior attention to details, smart provisions are made for easy serviceability and simplified maintenance that results into improved uptime. Extended engine compartment maintenance interval for higher uptime.



REMOTE MONITORING SYSTEM

Remote monitoring system, called EVI, installed in the machines helps in tracking various working parameters. This information can be used for improving site efficiency, maximizing operating performance while reducing maintenance costs. User can access the machine information through mobile for better machine management.



EXCELLENT PERFORMANCE

SANY SY215C-9 LC excavator is designed for excellent performance with combination of superior fuel economy and best in class productivity

SUPERIOR FUEL EFFICIENCY

- DYNAMIC OPTIMIZATION MATCHING CONTROL SYSTEM (DOMCS)**
DOMCS ensures quick response to the change of operating variables in order to achieve optimum engine performance as per the external load demand facilitating the optimum control of excavator external load operation system.
- WORK MODES AND AUTO IDLE**
SY215C-9 LC is equipped with four working modes (H, S, L, B) to match engine speed, pump speed and system pressure with versatile work application. Automatic idle function reduces fuel consumption significantly leading to reduced operating cost.

HIGH PRODUCTIVITY

- POWERFUL ENGINE**
SY215C-9 LC is powered by well proven indigenised Cummins engine with exceptional work capacity, enhanced maintainability and optimize fuel economy.
- ADVANCED HYDRAULIC SYSTEM**
When the machine deals with an operating requirement of moving heavy material quickly and efficiently, it needs the best hydraulic power that SY215C-9 LC offers.

The oil flow rate is directly proportional to the joystick operations and output pressure signal. It puts flow exactly where you need it, to facilitate smoother operation with great efficiency for higher productivity at optimized fuel economy. The advance control valve, which has been thoroughly optimized, provides excellent performance in combined operation.

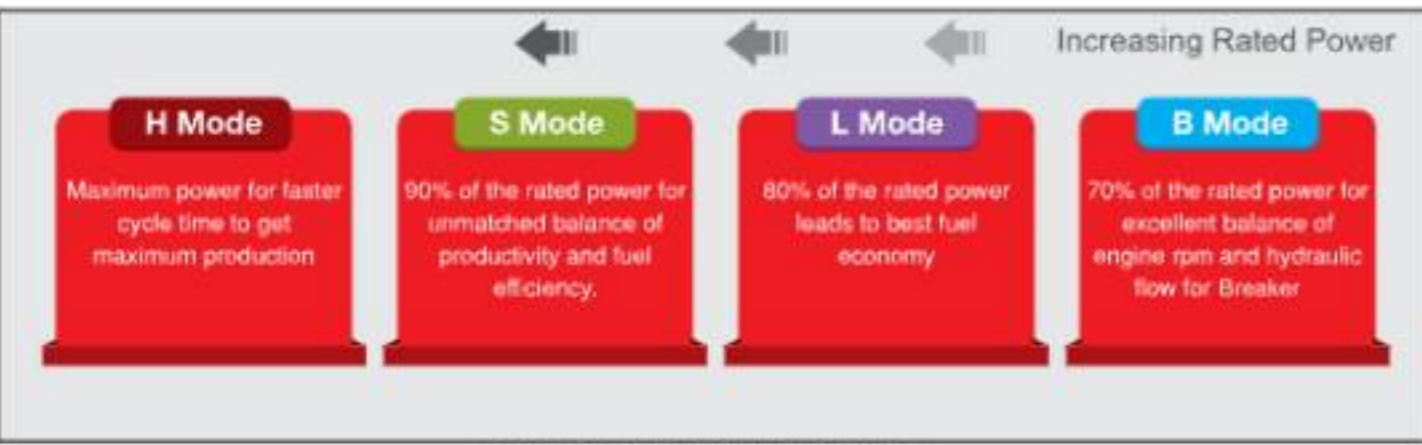

Optimized Power Mode System

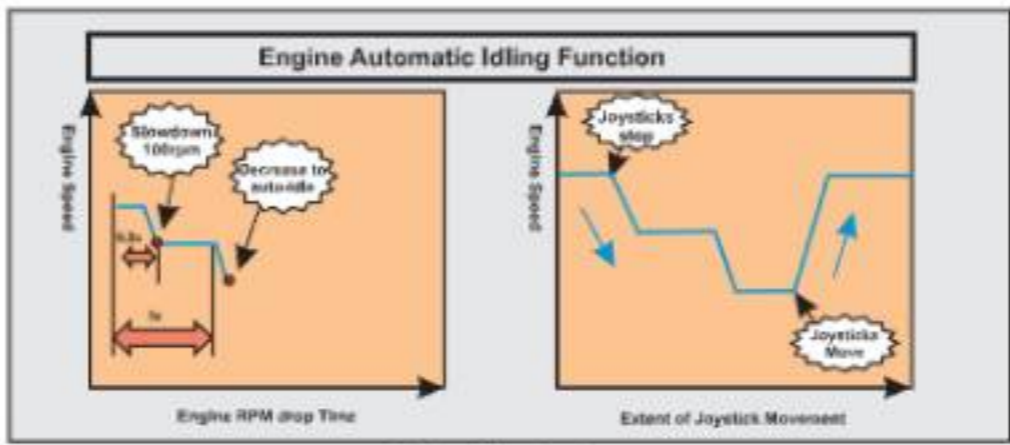

Auto Idle System

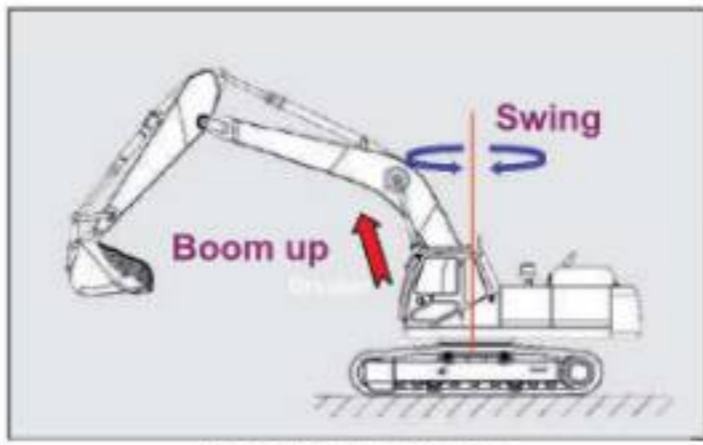

Boom Priority System

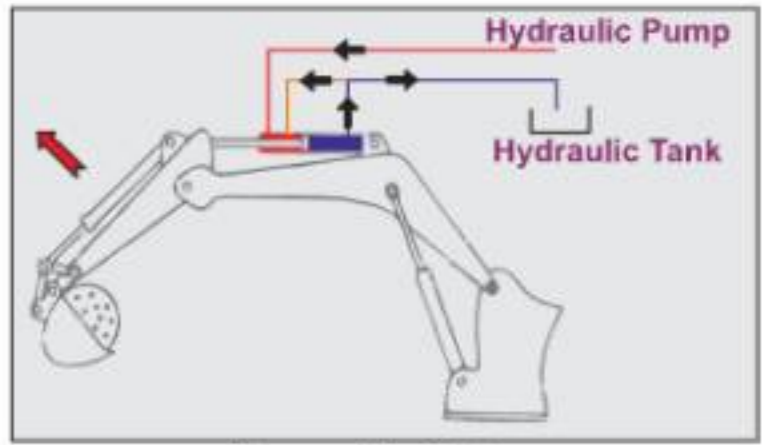

Regeneration System

HIGH RELIABILITY

The boom and arm is made up of large box-type structure welded with high strength steel sheet. Welded plates for excellent torsional resistance inside the structure leads to unmatched durability that prevents deformation under harsh conditions.

ROBUST STRUCTURE

- REINFORCED BOOM**
Robotically welded, heavy-duty boom is designed for best distribution of load throughout the boom structure which reduces lateral stress by 10% during the boom swing.
- REINFORCED ARM**
Arm's rear support is specially reinforced offering excellent torsional resistance imparting greater strength to the arm assembly for longer lifetime.
- WEAR RESISTANT BUCKET**
High strength bucket surface gives longer service life. Optimized design helps in reducing rock and sand resistance in turn decreases wear of the bucket body while digging.
- HIGH STRENGTH UPPER FRAME**
Heavy duty upper frame is designed to improve bending strength of the platform. D-shaped large section stronger beam can withstand external shocks.
- ENHANCED UNDERCARRIAGE**
Undercarriage is made up of high strength alloy steel with good wear resistance and durability.
- X-TYPE FRAME AND BOX TYPE STRUCTURE**
It has high strength and stiffness with excellent torsional and bending resistance. Reinforcing plate has been added to improve the strength of the lower frame. This improves working life.
- STRENGTHENED TRACK**
Anti-collision ribs have been added to improve its capacity of anti-deformation and protect the guide pulley.
Increased size of oil chamber of Idler improve performance of floating seal results into effective life.
Roller body is modified to heavy duty structure resulting into enhanced load bearing capacity.

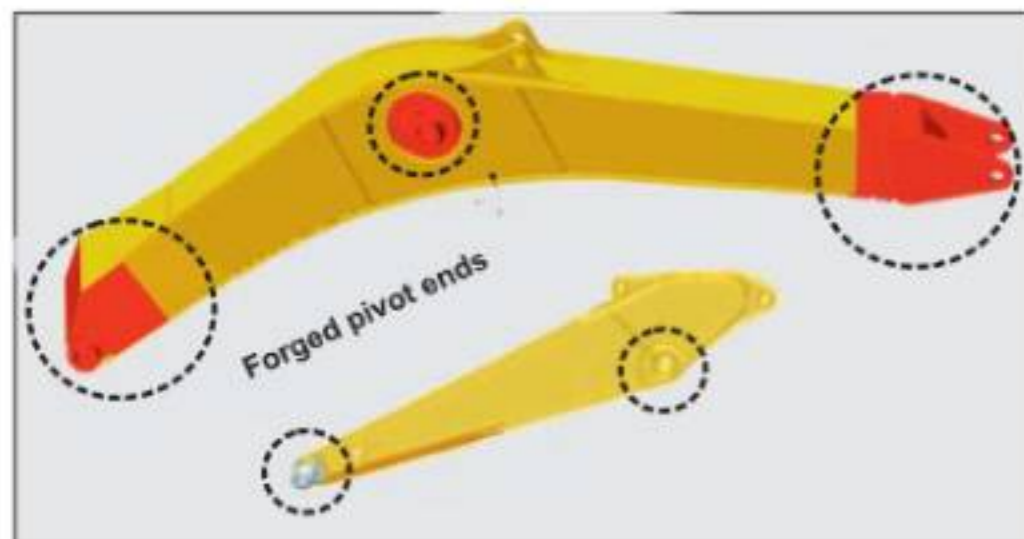

Heavy Duty Boom & Arm



Robust Bucket Design

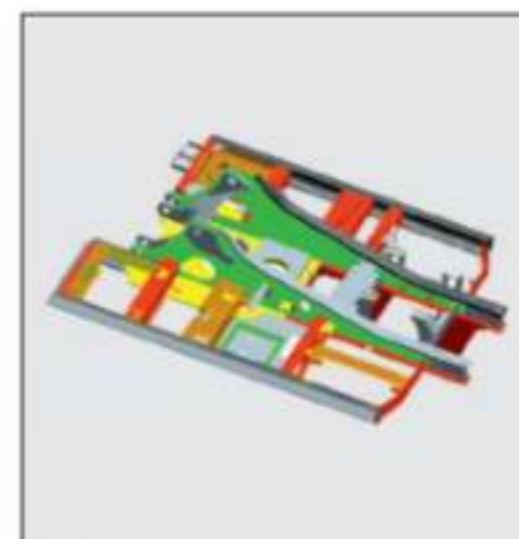

Upper Carriage with D shape design



HD Undercarriage with forged ring body



Improved Idler & strengthened undercarriage



BEST IN CLASS OPERATOR COMFORT & SAFETY

Newly designed spacious air conditioned cabin is equipped with weight indication adjustable suspension seat. Height, backrest inclination, armrest height, rear cushioning of the seat is designed for operator comfort. This reduces operator fatigue and enhances working efficiency.

COMFORT

MULTI-DUCT AUTO CLIMATE CONTROL AC SYSTEM

The standard large capacity air conditioner keeps in-cab air fresh by purification & recirculation which reduces operator fatigue.

ADVANCE SILICON RUBBER SHOCK ABSORBERS

Cabin bearing is attached to upper frame with silicone viscous shock absorber which effectively dampens vibrations while enhancing operator comfort.

PRESSURIZED HERMETIC CABIN

Cabin is air tight sealed and is dust free. It prevents dust entry into cabin gadgets by maintaining pressure variation between cabin and outside atmosphere.

ERGONOMICALLY DESIGNED JOYSTICK

Control levers and joysticks control are smartly designed for horizontal and vertical stroke of joystick for low lever effort.

HIGH STRENGTH ROOF TOP (WELL PROTECTED CABIN STRUCTURE)

The top plate of cabin is punch-formed with thick high-strength steel sheet integrated with reinforced ribs which offers excellent deformation-resistance resulting into operator safety in tough environments. SY215LC-9C comes with front & top guards which protect the cab & operator from flying debris.

CLEAR VISIBILITY

Larger windows of the newly-designed spacious cabin provide you with a wider view. The operator can clearly see the work equipment condition and the surrounding through the front, side and back windows.

SAFETY HEAT SHIELD AND FAN COVER

Turbocharger and engine radiator are insulated with heat resistant cover. Engine radiator fan is fully enclosed with wire-mesh to reduce risk of accidents.

OTHER SAFETY PROVISIONS

Operator's cabin is equipped with safety hammer, fire extinguisher, seat belt, protective fence, hydraulic pilot lock.



Auto Climate Control AC



Multi Duct AC



Fully Adjustable Suspension Seat



Low Effort Joystick



Silicon Viscous Shock Absorber



FOPS Cabin With Front & Top Guard



Enhanced All Round Visibility



Highly Protected Fan



Safety Hammer & Fire Extinguisher

EASE OF SERVICEABILITY

The use of OEM parts and quality elements effectively extends the service life and maintenance intervals. The time for maintenance is also reduced. Remote installation of replacement parts gives easy maintenance, higher utility and lower service cost.

EASY ACCESS

FILTER REPLACEMENT COMFORT

Access to the various filters (engine filter, pilot filter and A.C. filter) is very easy being mounted in hydraulic pump compartment for making cleaning easier. It comes with turbo air pre cleaner for enhanced filter replacement interval & higher engine life.

EASY CLEANING FOR RADIATOR

Radiator and oil cooler packing is easily washable which leads into excellent cooling capacity and ensures prolonged engine running without being overheated.

DRAIN PLUG ARRANGEMENT

Radiator, fuel tank, hydraulic tank and engine oil pan are provided with drain-plug at the bottom to flush out the debris and waste liquids at the time of oil replacement and cleaning. The tank bottom has drain plug guard to prevent physical damage.

TWO-LEVEL FUEL FILTER

The fuel filter system is conveniently placed for easy access with two level filtration and additional strainer filter which removes contamination from fuel. This kind of filtration system prolongs engine life.

EASE OF REGULAR CHECK UP

Regular performing components (swing gear greasing, engine oil and hydraulic oil) of the machine can be easily checked up which leads to time saving and long working ability.

LARGE LCD COLOR DISPLAY

Cabin is equipped with waterproof, dust proof and vibration proof anti-interference colour LCD display which provides real-time information regarding machine working status, abnormal alarm function etc. ensuring safe operation.

IMPROVED GREASING

Graphite infused bushes are provided for prolonged greasing interval. Centralized greasing points are provided for easy greasing of various points of boom assembly.

FLOATING BUSH PROVISION

Floating bush and shim arrangement are provided in bucket for easy and quick adjustment.



Specification	Service Interval
Engine oil	500 hrs
Engine oil filter	500 hrs
Fuel filter	500 hrs



Air Filter



AC Filter



Radiator



Drain Plug



Water Separator



Turbo Air Pre Cleaner



Engine Oil Level Check-up Access



Color Monitor



Graphite Bush



Centralized Greasing Points



Floating Bush Provision



EVI REMOTE MONITORING

EVI in SANY C-9 series excavators is a sophisticated system that helps you to remotely monitor wide range of excavator functions and access operating information.

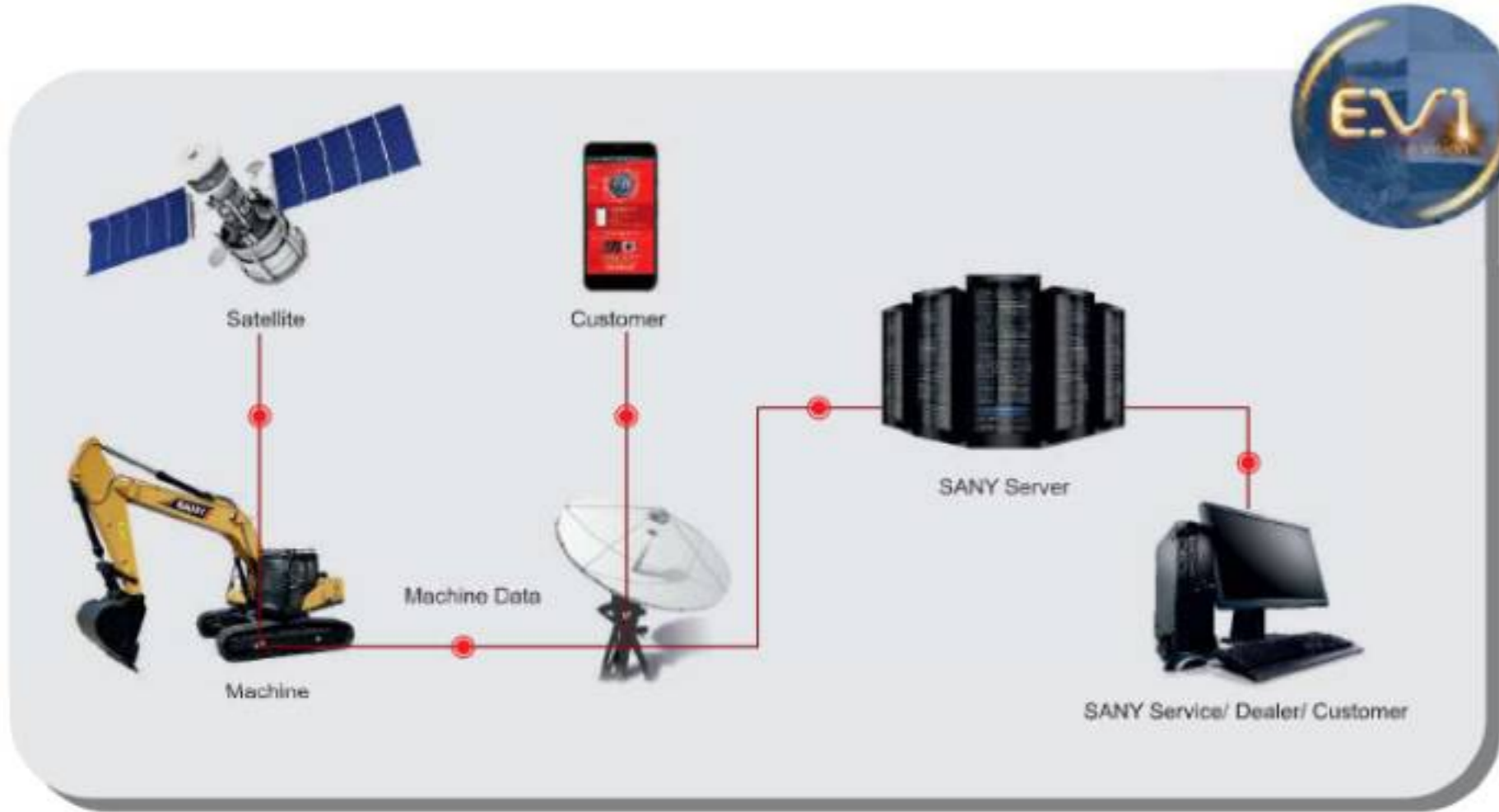

TECHNICAL SPECIFICATIONS

ENGINE	
Model	Cummins 6BT5.9-C140
Type	6 Cylinder, In-line, Water Cooled
Rated Engine Power	140HP(104kW) @ 2000 rpm
Max. Torque	571 N.m @ 1300rpm
Battery	2 X 12 V
Displacement	5.86L

CONTROL SYSTEM	
Control System	DOMCS Intelligent Controller
Working Modes	H S L B
Remote Monitoring System	GPRS, GPS, GIS

HYDRAULIC SYSTEM	
Main Pumps	2 Variable Displacement Axial Piston Pumps
Max. Flow	2 X 220 lpm
Pilot Pump	1 Gear Pump
Travel Motor	2 Axial Piston Motor with Parking Brake
Swing Motor	1 Axial Piston Motor with Swing Holding Brake

RELIEF VALVE SETTINGS	
Implement Circuit	34.3 Mpa
Swing Circuit	25.5 Mpa
Travel Circuit	34.3 Mpa
Pilot Circuit	3.9 Mpa

UNDERCARRIAGE & WORKING DEVICE	
Track Shoes (Each Side)	47
Upper Roller (Each Side)	2
Lower Roller (Each Side)	8
Track Guard (Each Side)	1
Std. Track	600 mm (12mm HD Track shoe Opt.)
Std. Boom	5700 mm
Std. Arm	2400 mm
Std. Bucket	1.1 m ³

PERFORMANCE	
Max. Travel Speed(High/Low)	5.4/3.3 km/h
Swing Speed	11 rpm
Grade ability	70% / 35°
Ground Pressure	47 kPa
Max. Tracking Force	209 kN
Bucket Digging Force	138 kN
Arm Digging Force	129 kN

SERVICE REFILL CAPACITIES		
Hydraulic Tank	230 L (Tank)	180 (Refill)
Fuel Tank	340 L	
Engine Oil	22.75 L	
Radiator	25.2 L	
Swing Device	4 L	
Travel Device	2x5.5 L	

CAB	
AC	Std.
Cabin Guard	Opt.

DIMENSION (Unit: mm)

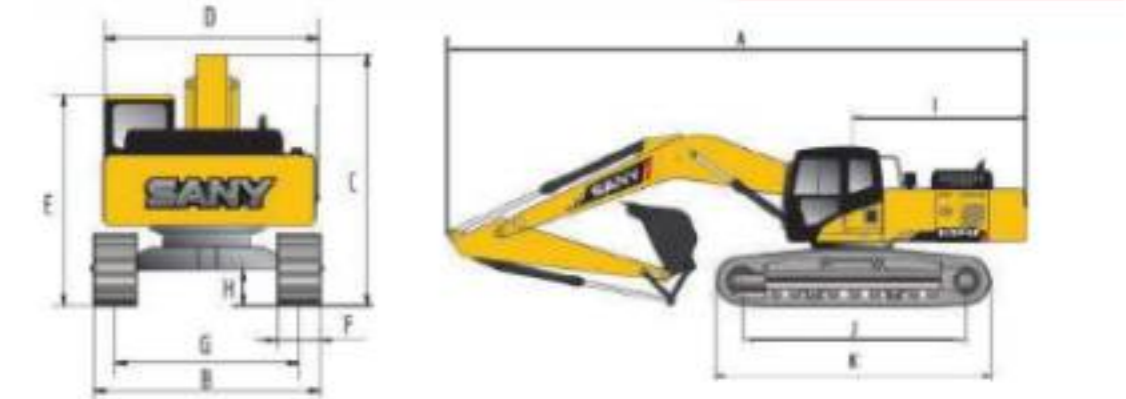

DIMENSION (Unit: mm)	Arm 2400	Arm 2900
A. Overall Length	9395	9430
B. Overall Width	2980	2980
C. Overall Height	2955	2955
D. Upper Width	2840	2840
E. Overall Height of Cab	2930	2930
F. Std. Track Shoe Width	600	600
G. Track Gauge	2380	2380
H. Min. Ground Clearance	465	465
I. Rear-end Swing Radius	2720	2720
J. Distance between Tumbles	3445	3445
K. Under Carriage Length	4250	4250

WORKING RANGE (Unit: mm)

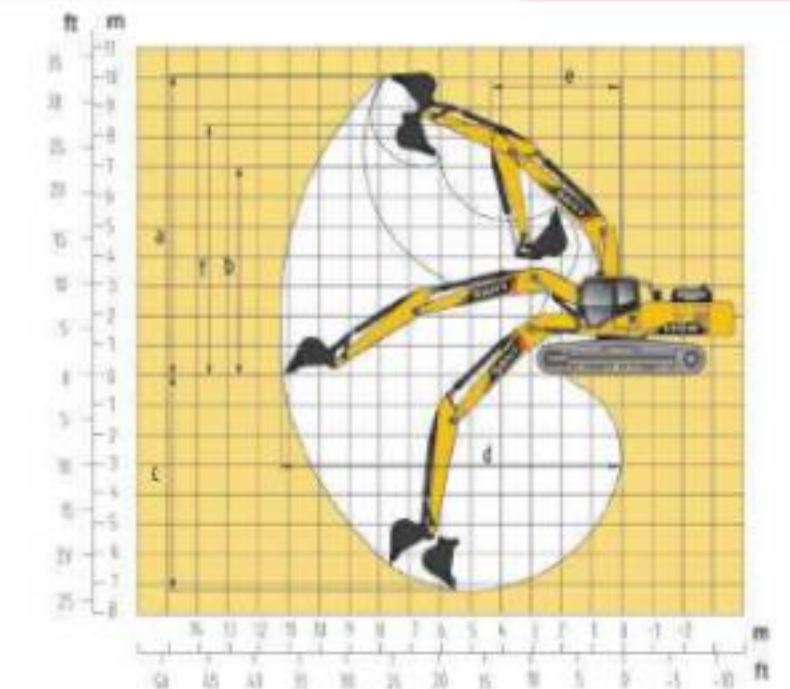

WORKING RANGE	Arm 2400	Arm 2900
a. Max. Cutting Height	9113	9600
b. Max. Dumping Height	6252	6730
c. Max. Digging Depth	6037	6600
d. Max. Digging Reach	9312	10280
e. Min. Swing Radius	3730	3730
f. Max. Height at Min. Swing Radius	7680	7680

BUCKET					
Capacity	Width (mm)	Weight (kg)	Tooth Point	Arm Length	
1.1 m ³ GP-Std.	1316	780	5	2.4	2.9
0.95 m ³ HD-Opt.	1176	870	4	✓	✓

REAL TIME NEWS UPDATES

Keep the customers always updated on Sany special offers, product upgrades & new product launches timely which help them to take right decision for maximum savings.

MACHINE OPERATING MANAGEMENT

Daily machine operation hours, non-working hours, engine idling time can be monitored and remaining fuel in the diesel tank can be determined.

REAL-TIME MONITORING

The real-time monitoring system displays various operating parameters like hydraulic oil pressure, engine rpm, working mode along with selected gear, coolant temperature, voltages and current etc.

LOCATION & TRACKING

Machine's current location can be captured for easy tracking. Route to working site of the machine can be determined as well. Dealer network also can be tracked through EVI app for quick contact if required.

LIFTING CAPACITY

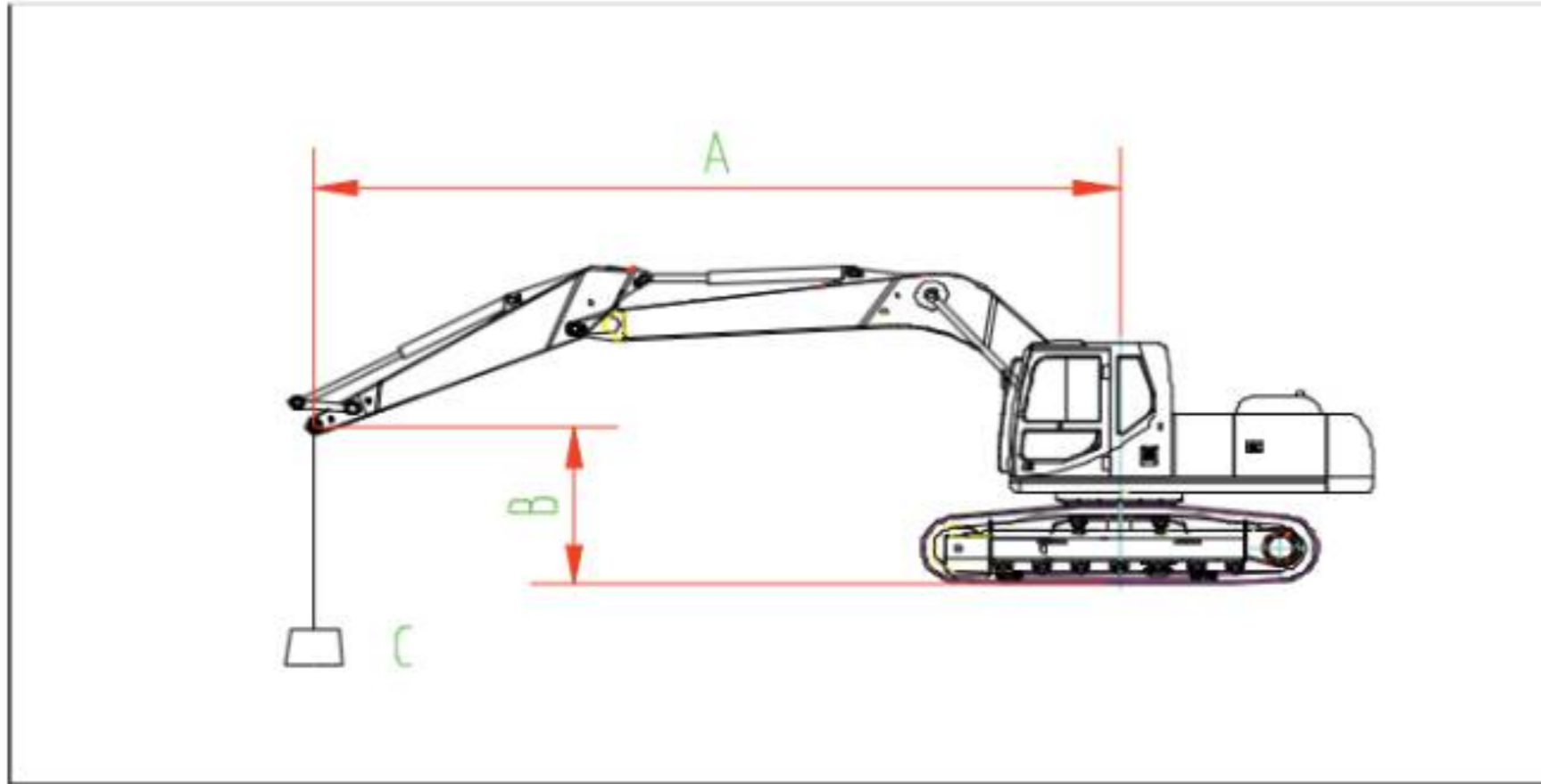

Rated Lifting Capacity (Kg)														
	A B	3.0m		4.5m		6.0m		7.5m		9.0m		Maximum		
		⚙️	⚙️	⚙️	⚙️	⚙️	⚙️	⚙️	⚙️	⚙️	⚙️	⚙️	mm	
Arm 2400mm	7.5m					4439.18	4439.18					3142.465	3142.465	6275
	6.0m					5210.522	4537.41					3143.332	3143.332	7360
Boom 5700mm	4.5m					5905.03	4373.15	4459.19	3062.399			3099.063	2717.326	8025
	3.0m													
Balance weight 4800kg	1.5m			9139.953	5758.752	5873.968	3892.034	4220.105	2843.081			3381.353	2388.325	8435
	0	6663.301	6663.301	8764.721	5442.325	5684.032	3722.658	4119.501	2750.794			3620.599	2430.011	8230
	-1.5m	10708.57	10108.33	8721.146	5405.579	5602.733	3650.16	4098.764	2731.772			3940.595	2634.005	7730
	-3.0m	16360.77	10294.27	8791.51	5464.916	5644.236	3687.17					4797.9	3216.179	6870
	-4.5m	14891.74	10667.45	9051.28	5683.976							6688.864	4372.786	5485

- Remarks:
1. Rated figure meets the criterion of GB/T 13331-2005/ISO 10576
 2. Rated rollover loading is 75% of static rollover loading, rated limiting hydraulic weight is 87% of limiting hydraulic weight.
 3. Loading radius is the distance from the loading point to the swing center.
 4. The figure with *stands for the rated figure of the limiting hydraulic weight.

PRESSURE AND CAPACITIES

WEIGHTS AND GROUND PRESSURE

Shoe type	Shoe width	Model SY215C-9 LC	
		Operating weight	Ground pressure
Triple grouser	600mm	21400 kg	47 Kpa

STANDARD EQUIPMENT

ENGINE

- Mode control (H, S, L and B)
- Start motor 24V/4.5KW
- Alternator 50A
- Turbo air pre-cleaner
- Dry double-filtering air cleaner
- Cylindrical engine oil filter
- Cylindrical fuel filter
- Engine oil cooler
- Radiator with protective screen
- Auxiliary water tank for radiator
- Fan cowl
- Separately installed engine
- Automatic deceleration system
- Accelerating system

UNDERCARRIAGE

- Travel brake
- Travel motor guard
- H-track guiding mechanism
- Hydraulic track tensioner
- Bolted sprocket
- Carrier roller and track roller
- Reinforced track link with pin and seal
- 600 mm track shoes
- Bottom cover plate
- Reinforced side pedal

SWING PLATFORM

- Fuel level float
- Hydraulic oil level gauge
- Toolbox
- Rear view mirror (R)
- Swing brake

HYDRAULIC SYSTEM

- Working mode selection switch
- Power enhancement device
- Control valve with main relief valve
- Spare oil port for control valve
- Oil suction filter
- Oil return filter
- Pilot filter

FRONT WORK EQUIPMENT

- Flange pin
- Bucket clearance adjustment
- Welded lever
- Central lubrication system
- Dust ring-seal of bucket pin
- Fully-welded box boom
- Fully-welded box arm
- Guard
- Standard bucket

OTHERS

- Standard battery
- Lockup engine hood
- Lockup fuel filler cap
- Anti-skid film, handhold and passage
- Travel direction mark
- Hand grease gun

OPERATOR STATION

- Noise proof steel-structured cab
- Toughened light-color window
- 6 silicone rubber damping support
- Operable roof hatch, upper front window and left window
- Rear window, alternate exit
- Silent window wiper with washer
- Adjustable inclined seat with adjustable armrest
- AM-FM radio with digital clock
- Foot rest and floor mat
- Loudspeaker, rear view mirror
- Seat belt and fire extinguisher
- Cup holder and cab light
- Ashtray alternate hammer
- Storage box, literature bag
- Hydraulic lockout control
- Cab visor
- Fully automatic air-conditioner

OPTIONAL

- Hydraulic Quick coupler
- 0.95 m³ HD bucket
- Cabin front and top guard
- Breaker piping kit
- 12mm Track Shoe