

ENGINE	STD	OPT
--------	-----	-----

Hyundai HM8.3 Engine	●	
----------------------	---	--

HYDRAULIC SYSTEM	STD	OPT
------------------	-----	-----

Intelligent Power Control (IPC)	STD	OPT
3-power mode, 2-work mode, user mode	●	
Variable power control	●	
Pump flow control	●	
Attachment mode flow control		●
Engine auto idle	●	
Engine auto shutdown control		●

CAB & INTERIOR	STD	OPT
----------------	-----	-----

ISO Standard Cabin	STD	OPT
Rise-up type windshield wiper	●	
Radio / USB player	●	
Handsfree mobile phone system with USB	●	
12 V power outlet (24 V DC to 12 V DC converter)	●	
Electric horn	●	
All-weather steel cab with 360° visibility	●	
Safety glass windows	●	
Sliding fold-in front window	●	
Sliding side window (LH)	●	
Lockable door	●	
Hot & Cool box	●	
Storage compartment & Ashtray	●	
Sun visor	●	
Door and cab locks, one key	●	
Pilot-operated slidable joystick	●	
Cabin lights		●
Cabin front window rain guard		●
Cabin roof-steel cover	●	
Automatic Climate Control	STD	OPT
Air conditioner & Heater	●	
Defroster	●	
Starting aid (air grid heater) for cold weather	●	
Centralized Monitoring	STD	OPT
8" LCD display - Normal type	●	
8" LCD display - Premium type		●
Engine speed or trip meter / Accel	●	
Engine coolant temperature gauge	●	
Max power	●	
Low speed / High speed	●	
Auto idle	●	
Overload	●	
Check engine	●	
Air cleaner clogging	●	
Indicators	●	
ECO gauges	●	
Fuel level gauge	●	
Hyd. oil temperature gauge	●	
Warnings	●	
Communication error	●	
Low battery	●	
Clock	●	
Seat	STD	OPT
Mechanical suspension without heater	●	
Mechanical suspension with heater		●
Adjustable air suspension without heater		●
Adjustable air suspension with heater		●
Cabin FOPS	STD	OPT
FOPS (Falling object protective structures)ISO 10262 Level 2		●
FOG (Falling object guard)	Front & Top guard	●
ISO 10262 Level 2	Top guard	●
Cabin ROPS	STD	OPT
ROPS (Roll over protective structures)ISO 12117-2		●

SAFETY	STD	OPT
--------	-----	-----

Battery master switch	●	
Rearview camera		●
AAVM (Advanced around view monitoring)		●
Six front working lights (4 boom mounted, 2 front frame mounted)	●	
Travel alarm	●	
Rear work lamp		●
Beacon lamp		●
Automatic swing brake	●	
Boom holding system	●	
Arm holding system	●	
Safety lock valve for boom cylinder with overload warning device		●
Safety lock valve for arm cylinder		●
Swing Lock system		●
Two outside rearview mirror	●	

OTHER	STD	OPT
-------	-----	-----

Booms	STD	OPT
6.45 m, 21' 2" Mono	●	
6.15 m, 20' 2" Mono		●
Arms	STD	OPT
2.2 m, 7' 3"		●
2.5 m, 8' 2"		●
3.2 m, 10' 6"	●	
Removable clean-out dust net for cooler	●	
Removable washer tank	●	
Fuel pre-filter	●	
Fuel warmer		●
Self-diagnostics system	●	
Hi-mate (Remote management system)		●
Batteries (2 × 12 V × 150 AH)	●	
Fuel filler pump (50 l/min)	●	
Single-acting piping kit (Breaker, etc.)	●	
Double-acting piping kit (Clamshell, etc.)	●	
Quick coupler piping	●	
Quick coupler	●	
Accumulator for lowering work equipment	●	
Fine swing control system		●
General type guardrail		●
Tool kit		●

UNDERCARRIAGE	STD	OPT
---------------	-----	-----

Lower frame under cover (Additional)		●
Lower frame under cover (Normal)	●	
Track Shoes		
Triple grouser shoes (600 mm, 24")	●	

- Standard and optional equipment may vary. Contact your Hyundai dealer for more information. The machine may vary according to international standards.
- The photos may include attachments and optional equipment that are not available in your area.
- Materials and specifications are subject to change without advance notice.
- All imperial measurements rounded off to the nearest pound or inch.



Hyundai Construction Equipment India Pvt. Ltd.
 Plot No. A-2, M. I. D. C. Chakan, Phase II,
 Village: Khalumbre, Taluka: Khed, Dist: Pune - 410501
 E mail: hyundai.care@theconnectionsindia.com
 Tel.No.: 02135 301700 Fax No: 02135 301712 Toll Free No.: 1800 209 8600
 www.hyundaiindia.net @hceindia f/hyundaiindia.net/
 @hyceindia Hyundai Construction Equipment India Pvt Ltd

PLEASE CONTACT

www.hyundai-ce.com

MOVING YOU FURTHER

HX360L

With Tier 2 / Stage II Engine Installed

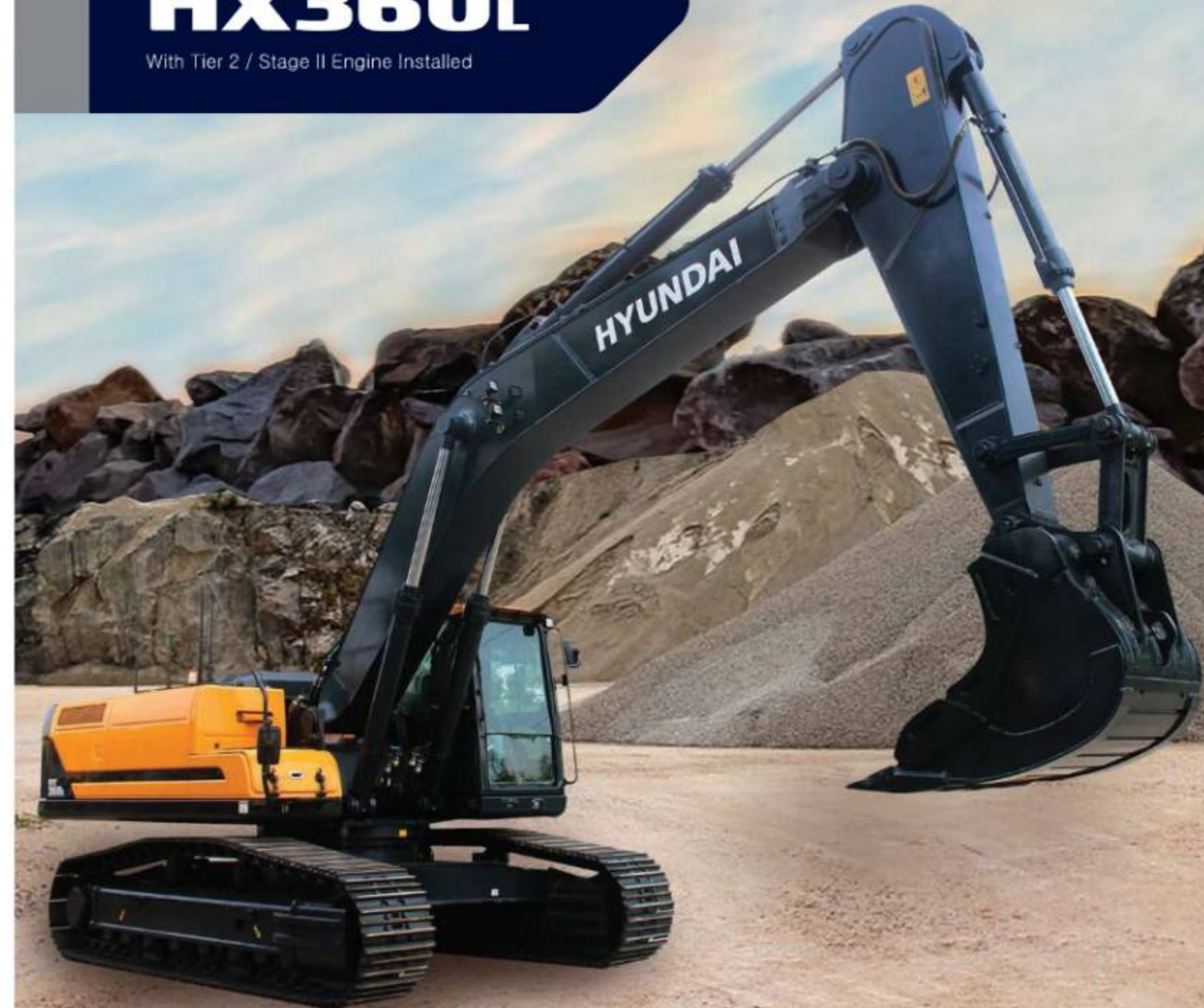

Gross Power SAE J1955 / 250 HP (186 kW) at 2,200 rpm	Travel Speed 6.4 km/hr (3.98 mph) / 3.6 km/hr (2.11 mph)	Operating Weight 35,050 kg
---	---	-------------------------------



The HX Series Excavators are products of HCE's spirit of initiative, creativity, and strong drive. HCE's engineers, who are the best in the industry, have worked tirelessly to offer a zero-defect product. The new HX Series reflects customers' needs in the field gleaned by thorough monitoring. They maximize fuel efficiency and performance proven by rigorous field tests and quality control.

MOVING YOU FURTHER



*Photo may include optional equipment.

RULE THE GROUND

The HX Series exceeds customer's expectation!
Become a true leader on the ground with HCE's HX Series.

HX360L



WORK MAX, WORTH MAX

- New Variable Power Control
- Fuel Rate Information (Option)
- IPC (Intelligent Power Control)
- Attachment Flow Control (Option)
- ECO Gauge
- New Cooling System with Increased Air Flow
- Enlarged Air Inlet with Grill Cover
- Cycle Time Improvement



MORE RELIABLE, MORE SUSTAINABLE

- Durable Cooling Module
- Reinforced Pin, Bush, and Polymer Shim
- Reinforced Durability of Upper and Lower Structure and Attachments
- Wear Resistant Cover Plate
- Hi-grade (High-pressure) Hoses



INFOTAINMENT FRONTIER

- New Front Side Air Conditioning Systems
- Intelligent and Wide Cluster
- New Air Conditioning System
- Wi-Fi Direct with Smart Phone (Miracast) (Option)
- Proportional Auxiliary Hydraulic System (Option)
- Quick Coupler Button (Option)
- New Audio System



MODERN COMFORT, SIMPLE AND SAFE SOLUTION

- AAM (Advanced Around View Monitoring) Camera System (Option)
- Hi-mate (Remote Management System) (Option)
- Cab Suspension Mount
- Swing Lock System (Option)
- Fine Swing Control (Option)



*Photo may include optional equipment.



*Photo may include optional equipment.

New Variable Power Control

The HX Series minimizes equipment input and output control signals to improve fuel efficiency. Its three-stage power mode ensures the highest performance in any operating environment.



• P (power) mode : Maximizes speed and power of the equipment for heavy load work.



• S (standard) mode : Optimizes performance and fuel efficiency of the equipment for general load work.



• E (economy) mode : Improves the control system for light load work.

WORK MAX, WORTH MAX

Fuel Efficient System, Allows Great Performance

The HX Series has an eco-friendly, high-performance engine which ensures both excellent fuel efficiency and high power. With outstanding operating performance proven by rigorous tests at various work sites, it will satisfy any customer's needs.

15% increased greater screen from 7 to 8 inch is applied in HX Series. More functions and better resolution are available with adding premium options.



Fuel Rate Information (Option)

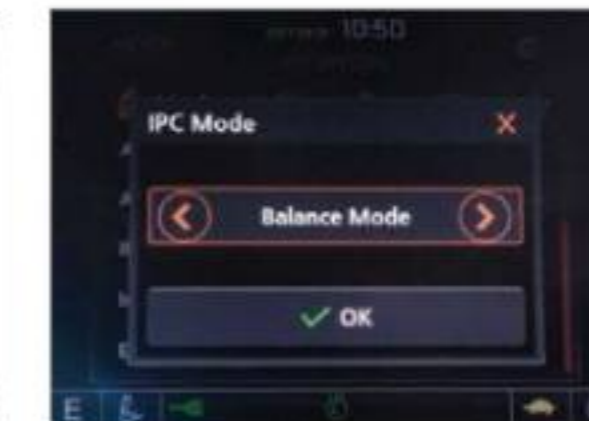

IPC (Intelligent Power Control)

The IPC controls power depending on work environments. Its mode can be selected and released on the monitor. On the excavation mode, pump flow can be easily controlled by a lever, reducing fuel consumption.



Attachment Flow Control (Option)

The HX Series improves pump flow rate by independent control of two pumps. It optimizes attachments for effective flow rate setting depending on attachments (ten breaker types and ten crusher types), enabling various operations matching the site environments.



Eco Gauge

Eco gauge enables economic operation of machines. The gauge level and color displays engine torque and fuel efficiency level. On top of that, the status of fuel consumption such as average rate and the total amount of fuel consumed is displayed. Hourly and daily based fuel consumption can be checked in the detailed menu as well.



New Cooling System with Increased Air Flow

With the cooling module improving air inflow, the HX Series provides excellent cooling performance by increasing heat dissipation.



Enlarged Air Inlet with Grill Cover

Enlarged vent hole of the air inlet side cover and fine net grill to prevent penetration of foreign materials further improve durability.

Cycle Time Improvement

The HX Series provides higher productivity on the site by faster operation: It loads trucks up to 10% faster and levels up to 15% faster than the 99 Series.

MORE RELIABLE, MORE SUSTAINABLE

New Exterior Design for Robustness and Safety

The true value of the HX Series lies in its durability. The robust frame structure and the attachments show the real value of the HX Series in tough working environments and promise higher productivity.



Durable Cooling Module

The HX Series has a durable cooling module that passed stringent tests, demonstrating the highest productivity in tough working environments.



Chrome Coated Pins

Reinforced Pin, Bush, and Polymer Shim

The HX Series improves lubricity of connecting parts between the equipment and attachments. Gaps with attachments are minimized by wear-resistant long-life pins, bushes, and polymer shims, supporting the highest performance with invariable durability.

Wear Resistant Cover Plate

A wear-resistant cover plate is installed at the end of the arm to minimize abrasion on the connector between the arm and the bucket. Vibration reduction of buckets enables more stable operation even in high-load work.



Reinforced Durability of Upper and Lower Structure and Attachments

The upper and lower structure and attachments of the HX Series have higher durability than demanded on the site, as proven through numerous tests including road tests and virtual simulation. The wear resistance of the bucket has been improved by use of new material.



*Photo may include optional equipment.

Hi-grade (High-pressure) Hoses

The HX Series uses high-pressure hoses with improved heat and pressure resistance, greatly increasing the durability of the equipment.



Cabin space for drivers increased by
13%
(Compared to 9S Series)

310 mm
(9S Series)

340 mm
(HX Series)

*Photo may include optional equipment.



New Front Side Air-conditioning System
The ventilation is designed for both warm and cool air reaching to operators' faces. It could help operators create more neat and enjoyable atmosphere through indoor air circulation.

INFOTAINMENT FRONTIER

Improved Instrument Panel for Easier Monitoring

Many electronic functions are concentrated in the most convenient spot for operators to improve work efficiency. The highly-advanced infotainment system, a product of HCE's intensive information technology development, enables both productivity and comfort while working! The HX Series is designed with the operator in mind.



Intelligent and Wide Cluster
The 8-inch interactive touchscreen display of the HX Series is 15% larger than that of the previous model. The centralized switches on the display allow the operator to check the urea level and the temperature outside the cab.



New Air Conditioning System
Front side Air Vent holes make operators more convenient and fresh through direct air flow to driver's face, foot and body.



Proportional Auxiliary Hydraulic System (Option)
Proportional control switch for better speed control
Enlarge the operation convenience

Wi-Fi Direct with Smart Phone (Miracast) (Option)
The smart terminal-miracast system uses the Wi-Fi from the operator's smart phone to easily and conveniently enable features of the smart phone, such as navigating, surfing the web, watching videos, and listening to music, on the 8" screen. (Currently only available for Android phones.)



Front Side Air-Vent

Quick Coupler Button (Option)

Easy attachment replacement of equipment is available with quick coupler button.

New Audio System

The radio player with a USB-based MP3 player, an integrated Bluetooth hands-free feature, and a built-in microphone allow for phone calls while at work and in transit. The radio player is conveniently located on the right side of the operator to allow for improved access.



MODERN COMFORT, SIMPLE AND SAFE SOLUTION

New Cabin for More Comfort

Low noise, low vibration, and ergonomic design make the cabin space more comfortable and pleasant! With focus on safety and convenience of operators, the HX Series allows rapid and safe equipment inspection anytime and anywhere, providing an optimal environment for operators to work.



AAVM (Advanced Around View Monitoring) Camera System (Option)

The HX Series has a state-of-the-art AAVM video camera system to secure field of vision for operators in all directions, thereby preventing accidents. Operators can easily check the workplace in the front and rear and to the right and left.



- AVM (Around View Monitoring): Secure field of vision in all directions by nine views including 3D bird's eye view and 2D/4CH view.
- IMOD (Intelligent Moving Object Detection): Inform when people or dangerous objects are detected within the range of operation (Recognition distance: 5m).

HiMATE

It's Convenient, Easy and Valuable

Hi-mate Hyundai's newly developed remote management system, utilizes GPS-satellite technology to provide customers with the highest level of service and product support available. Hi-mate enables users to remotely evaluate machine performance, access diagnostic information, and verify machine locations at the touch of a button.

What is benefits



Increase Productivity

It helps you operate machines in efficient. You can check the difference between total engine hours and actual working hours. See how productive your machines are and plan any required cost saving solutions. Hi MATE offers working information such as working / idling hours, fuel consumption and rate.



Convenient and Easy Monitoring

There is nothing much to do to monitor your machines. Just log on to the HiMATE website or mobile application. Hi MATE allows you to watch your machines whenever and wherever you are.



Security

Protect your machines from theft or unauthorized usage with Hi MATE. If the machine moves out of the Geo-fence boundary, you will get alerts.

HiMATE

REMOTE MANAGEMENT SYSTEM

Our Unique remote management system allows customers to access machine operating information & obtain service & maintenance alerts at the touch of a button.

INCREASED PRODUCTIVITY

Hi MATE empowers you to enhance the efficiency of your operations. Make better decisions by comparing the machine's operating time with its travelling, idling & breaker use duration.

CONVENIENT & EASY MONITORING

Enjoy round the clock & on the move access to your machine's information through the website or the mobile app.



SECURITY & FLEET MONITORING

Protect your machines from theft or unauthorized use. Hi MATE's GPS feature allows you to create a geo-fence & alerts you if the machine moves out of the defined boundary.

Item	Default	Setting	Total	At the last maintenance	Notice	Setting	Replace
Engine Oil	500	62	22	833	25-Apr-2018		100
Travel Reducer Gear Case	1,800	300	0	400	15-Jan-2018		200
Swing Reducer Gear Case	1,800	300	0	400	15-Jan-2018		400
Hydraulic Oil	5,000	350	0	554	07-Feb-2018		95
Hot Line Filter	1,800	220	0	340	02-Feb-2018		240
Hydraulic Tank Drain Filter	1,800	250	0	340	02-Feb-2018		210

PROACTIVE MAINTENANCE

Access your machine's service & maintenance history with the utmost convenience. Plan your service schedules intelligently with our regular reminders.

Date	Time	Hourmeter	Alarm Type	Alarm Code (SPN)	Description	Codebook
15-Apr-2018	07:16	510	W	301	Warning! Fuel level low	
16-Apr-2018	17:26	509	W	301	Warning! Fuel level low	
15-Apr-2018	11:23	491	W	301	Warning! Fuel level low	
16-Apr-2018	07:14	484	W	301	Warning! Battery Voltage low	
08-Apr-2018	07:43	475	W	301	Warning! Fuel level low	
08-Apr-2018	08:20	476	W	301	Warning! Fuel level low	
08-Apr-2018	11:24	460	W	311	Warning! Engine Oil Pressure low	

ALARMS

Get notified of system alarms & protect your machine from critical faults & experience repairs.

*OPTIONAL EQUIPMENT



RECEIVE LIVE NOTIFICATION THROUGH SMS & HiMATE APPLICATION ALERTS

SPECIFICATIONS

ENGINE

Maker / Model	HYUNDAI HM8.3	
Type	Watercooled, 4-cylinder diesel, 6-cylinders in line, direct injection, turbocharged, charger air cooled, low emission	
Rated flywheel horse power	SAE J1995 (gross)	250 HP (186kW) at 2,200 rpm
	J1349 (net)	245 HP (183kW) at 2,200 rpm
Max. Power	265 HP (198kW) at 2,000 rpm	
Max. torque	124 kgfm (899 lbf-ft) at 1,300 rpm	
Bore × Stroke	114 mm × 135 mm (4.49" × 5.31")	
Piston displacement	8,290 cc (506 cu in)	
Batteries	2 × 12 V × 150 Ah	
Starting motor	24 V × 7.2 kW	
Alternator	24 V × 90 A	

HYDRAULIC SYSTEM

MAIN PUMP	
Type	Variable displacement tandem axis piston pumps
Max. flow	2 × 306 l/min
Sub-pump for pilot circuit	Gear pump
Cross-sensing and fuel saving pump system.	

HYDRAULIC MOTORS	
Travel	Two speed axial pistons motor with brake valve and parking brake
Swing	Axial piston motor with automatic brake

RELIEF VALVE SETTING	
Implement circuits	350 kgf/cm ² (4,980 psi)
Travel	350 kgf/cm ² (4,980 psi)
Powerboost (boom, arm, bucket)	380 kgf/cm ² (5,400 psi)
Swing circuit	300 kgf/cm ² (4,270 psi)
Pilot circuit	40 kgf/cm ² (570 psi)
Service valve	Installed

HYDRAULIC CYLINDERS	
No. of cylinder bore X stroke	Boom: 2-∅150 × 1,480 mm
	Arm: 1-∅160 × 1,685 mm
	Bucket: 1-∅140 × 1,285 mm

DRIVES & BRAKES

Drive method	Fully hydrostatic type
Drive motor	Axial piston motor, in-shoe design
Reduction system	Planetary reduction gear
Max. drawbar pull	29,500 kgf (65,030 lbf)
Max. travel speed (high / low)	6.4km/hr (3.98mph)/3.6km/hr(2.11mph)
Gradeability	35° (70%)
Parking brake	Multi wet disc

CONTROL

Pilot pressure operated joysticks and pedals with detachable lever provide almost effortless and fatigueless operation.	
Pilot control	Two joysticks with one safety lever (LH): Swing and arm. (RH): Boom and bucket (ISO)
Travelling and steering	Two levers with pedals
Engine throttle	Electric, dial type

SWING SYSTEM

Swing motor	Fixed displacement axial piston motor
Swing reduction	Planetary gear reduction
Swing bearing lubrication	Grease-bathed
Swing brake	Multi wet disc
Swing speed	11.2 rpm

COOLANT & LUBRICANT CAPACITY

	liter
Fuel tank	600
Engine coolant	25
Engine oil	26.5
Swing device	11
Final drive (each)	8.0 (7.8)
Hydraulic system (including tank)	414
Hydraulic tank	210

UNDERCARRIAGE

The X-leg type center frame is integrally welded with reinforced box-section track frames. The undercarriage includes lubricated rollers, idlers, track adjusters with shock absorbing springs and sprockets, and a track chain with triple grouser shoes.

Center frame	X-leg type
Track frame	Pentagonal box type
No. of shoes on each side	48 EA
No. of carrier roller on each side	2 EA
No. of track roller on each side	9 EA
No. of rail guard on each side	2 EA

OPERATING WEIGHT (APPROXIMATE)

Operating weight, including 6,450mm (21' 2") boom, 2.5mts (10' 6") arm, SAE heaped 1.44m³ (1.88yd³) bucket, lubricant, coolant, full fuel tank, full hydraulic tank, and all standard equipments.

OPERATING WEIGHT			
Shoes	Operating weight		Ground pressure
Type	Width mm	kg (lb)	kgf/cm ² (psi)
Triple grouser	600	HX360L 35,050(kg)	0.64 (9.03)



AIR CONDITIONING SYSTEM

The air condition system for the machine contains the fluorinated greenhouse gas with global warming potential of R134a. (Global warming potential : 1,430)
The system hold 0.8kg refrigerant consisting of a CO₂ equivalent 1.14 kg metric tonne. For more information, please refer to the manual.

BUCKET SELECTION GUIDE & DIGGING FORCE

BUCKETS

All buckets are welded with high-strength steel.

			
SAE heaped m ³ (yd ³)	1.44 1.74 2.10	◆1.44	⊗1.44 ⊗1.60 (HD) ⊗1.73 ⊗1.83 (HD)

Capacity m ³ (yd ³)	Width mm (in)	Weight kg (lb)	Tooth	Recommendation mm (ft-in)				
				6,150 (20' 2") Boom	6,450 (21' 2") Boom			
SAE heaped	CECE heaped			2,200 (7' 3") Arm	2,200 (7' 3") Arm	2,500 (8' 2") Arm	3,200 (10' 6") Arm	
2.10 (2.75)	1.80 (2.35)	1,910 (75.2")	1,650 (3,640)	6	●	●	●	▲
⊗ 1.44 (1.88)	1.25 (1.63)	1,470 (57.9")	1,485 (3,270)	5	●	●	●	○

- ◆ Heavy duty bucket
- ⊗ Rock-Heavy duty bucket
- : Applicable for materials with density of 2,100 kgf/m³ (3,500 lbf/yd³) or less
- : Applicable for materials with density of 1,800 kgf/m³ (3,000 lbf/yd³) or less
- : Applicable for materials with density of 1,500 kgf/m³ (2,500 lbf/yd³) or less
- ▲ : Applicable for materials with density of 1,200 kgf/m³ (2,000 lbf/yd³) or less

ATTACHMENT

Booms and arms are welded with a low-stress, full-box section design. 6.15m, 6.45m Booms and 2.2m, 2.5m

DIGGING FORCE

Boom	Length	mm (ft-in)	6,150 (20' 2")		6,450 (21' 2")		Remark
			Weight kg (lb)	2,950 (6,500)	3,030 (6,680)		
Arm	Length	mm (ft-in)	2,200 (7' 3")		2,500 (8' 2")		3,200 (10' 6")
			Weight kg (lb)	1,560 (3,440)	1,560 (3,440)	1,650 (3,640)	
Bucket digging force	SAE	kN	186.3 [203.3]	186.3 [203.3]	187.3 [204.4]	188.3 [205.5]	[] : Power Boost
		kgf	19,000 [20,730]	19,000 [20,730]	19,100 [20,840]	19,200 [20,950]	
		lbf	41,890 [45,700]	41,890 [45,700]	42,110 [45,940]	42,330 [46,190]	
	ISO	kN	214.8 [234.3]	214.8 [234.3]	215.7 [235.4]	216.7 [236.4]	
		kgf	21,900 [23,890]	21,900 [23,890]	22,000 [24,000]	22,100 [24,110]	
		lbf	48,280 [52,670]	48,280 [52,670]	48,500 [52,910]	48,720 [53,150]	
Arm crowd force	SAE	kN	195.2 [212.9]	195.2 [212.9]	175.5 [191.5]	140.2 [153.0]	
		kgf	19,900 [21,710]	19,900 [21,710]	17,900 [19,530]	14,300 [15,600]	
		lbf	43,870 [47,860]	43,870 [47,860]	39,460 [43,060]	31,530 [34,390]	
	ISO	kN	205.0 [223.6]	205.0 [223.6]	184.4 [201.1]	145.1 [158.4]	
		kgf	20,900 [22,800]	20,900 [22,800]	18,800 [20,510]	14,800 [16,150]	
		lbf	46,080 [50,270]	46,080 [50,270]	41,450 [45,220]	32,630 [35,600]	

Note : Boom weight includes arm cylinder, piping, and pin
Arm weight includes bucket cylinder, linkage, and pin

DIMENSIONS & WORKING RANGE

HX360L DIMENSIONS

6.45 m (21' 2"), 6.15 m (20' 2") BOOM and 2.2 m (7' 3"), 2.5 m (8' 2")

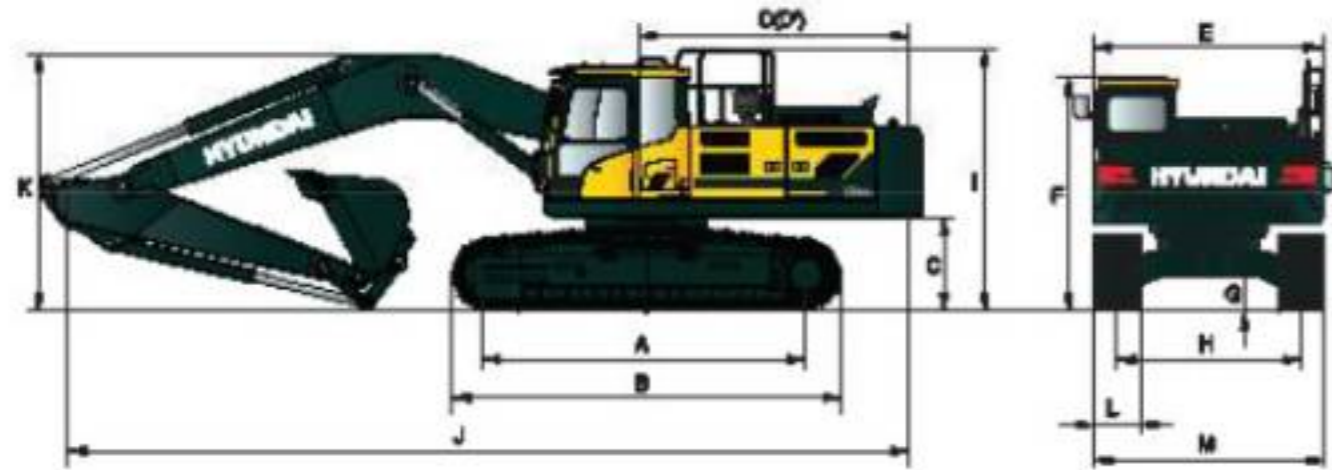

Unit : mm (ftin)

A	Tumbler distance	4,030 (13' 3")
B	Overall length of crawler	4,940 (16' 2")
C	Ground clearance of counterweight	1,200 (3' 11")
D	Tail swing radius	3,570 (11' 9")
D'	Rear-end length	3,510 (11' 6")
E	Overall width of upperstructure	2,980 (9' 9")
F	Overall height of cab	3,145 (10' 4")
G	Min. ground clearance	500 (1' 8")
H	Track gauge	2,680 (8' 10")
I	Overall height of guardrail (Opt)	3,350 (11' 0")

Boom length	6,150 (20' 2")	6,450 (21' 2")		
Arm length	2,200 (7' 3")	2,200 (7' 3")	2,500 (8' 2")	3,200 (10' 6")
J Overall length	11,160 (36' 7")	11,460 (37' 7")	11,340 (37' 2")	11,220 (36' 10")
K Overall height of boom	3,670 (12' 0")	3,630 (11' 11")	3,540 (11' 7")	3,350 (11' 0")
L Track shoe width	600 (24")	700 (28")		
M Overall width HX330SL	3,280 (10' 9")	3,380 (11' 1")		

HX360L WORKING RANGE

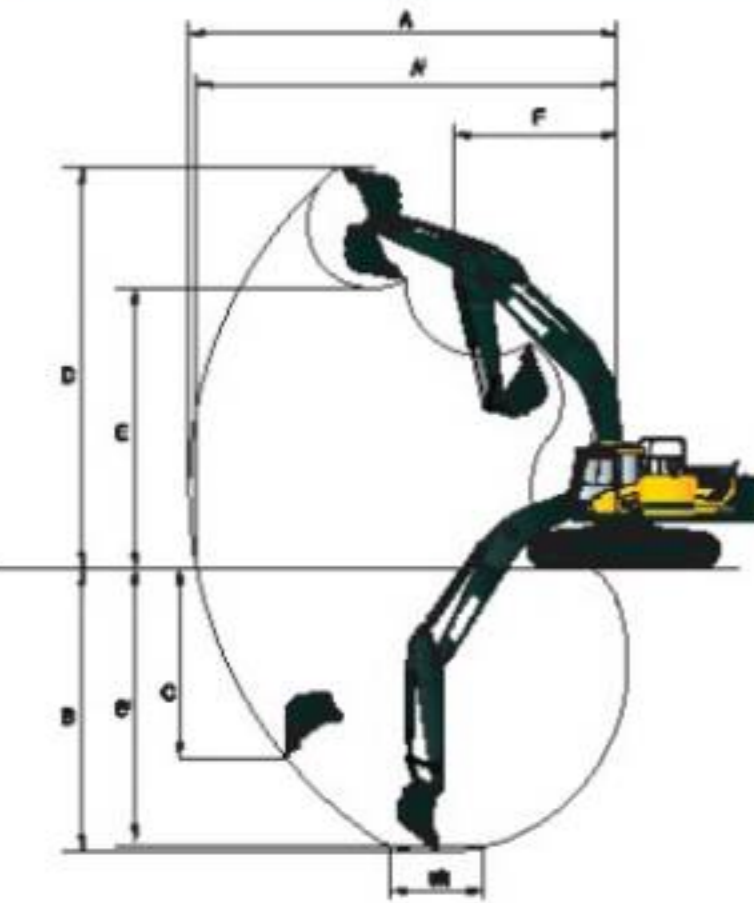

Unit : mm (ftin)

Boom length	6,150 (20' 2")	6,450 (21' 2")			
Arm length	2,200 (7' 3")	2,200 (7' 3")	2,500 (8' 2")	3,200 (10' 6")	4,050 (13' 3")
A Max. digging reach	10,020 (32' 10")	10,330 (33' 11")	10,500 (34' 5")	11,150 (36' 7")	11,950 (39' 2")
A' Max. digging reach on ground	9,810 (32' 2")	10,120 (33' 2")	10,290 (33' 9")	10,950 (35' 11")	11,770 (38' 7")
B Max. digging depth	6,150 (20' 2")	6,360 (20' 10")	6,680 (21' 10")	7,360 (24' 2")	8,210 (26' 11")
B' Max. digging depth (8' level)	5,950 (19' 6")	6,170 (20' 3")	6,450 (21' 2")	7,200 (23' 7")	8,080 (26' 6")
C Max. vertical wall digging depth	5,700 (18' 8")	5,970 (19' 7")	5,660 (19' 5")	6,330 (20' 9")	7,240 (23' 9")
D Max. digging height	9,980 (32' 9")	10,260 (33' 8")	10,050 (33' 0")	10,360 (34' 0")	10,780 (35' 4")
E Max. dumping height	6,790 (22' 3")	7,060 (23' 2")	6,950 (22' 10")	7,260 (23' 10")	7,670 (25' 2")
F Min. swing radius	4,450 (14' 7")	4,630 (15' 2")	4,440 (14' 7")	4,360 (14' 4")	4,290 (14' 1")

LIFTING CAPACITY

☺ 1g over-front ☻ 1g over-side or 360 degree

HX360L

6.15 m (20' 2") boom, 2.2 m (7' 3") arm equipped with 600 mm (24") triple grouser shoe and 6,000kg (13,230 lb) counterweight.

Load point height m (ft)		Load radius								At max. reach			
		1.5m (4.9ft)		3.0m (9.8ft)		4.5m (14.8ft)		6.0m (19.7ft)		7.5m (24.6ft)		Capacity	Reach
		☺	☻	☺	☻	☺	☻	☺	☻	☺	☻	kg	m (ft)
7.5 m (24.6ft)	kg												
	lb												
6.0 m (19.7ft)	kg												
	lb												
4.5 m (14.8ft)	kg												
	lb												
3.0 m (9.8ft)	kg												
	lb												
1.5 m (4.9ft)	kg												
	lb												
Ground Line	kg												
	lb												
-1.5 m (-4.9ft)	kg												
	lb												
-3.0 m (-9.8ft)	kg												
	lb												

6.45 m (21' 2") boom, 2.2 m (7' 3") arm equipped with 600 mm (24") triple grouser shoe and 6,000kg (13,230 lb) counterweight.

Load point height m (ft)		Load radius								At max. reach			
		1.5m (4.9ft)		3.0m (9.8ft)		4.5m (14.8ft)		6.0m (19.7ft)		7.5m (24.6ft)		Capacity	Reach
		☺	☻	☺	☻	☺	☻	☺	☻	☺	☻	kg	m (ft)
7.5 m (24.6ft)	kg												
	lb												
6.0 m (19.7ft)	kg												
	lb												
4.5 m (14.8ft)	kg												
	lb												
3.0 m (9.8ft)	kg												
	lb												
1.5 m (4.9ft)	kg												
	lb												
Ground Line	kg												
	lb												
-1.5 m (-4.9ft)	kg												
	lb												
-3.0 m (-9.8ft)	kg												
	lb												
-4.5 m (-14.8ft)	kg												
	lb												











- Lifting capacity are based on ISO 10567.
- Lifting capacity of the Robex Series does not exceed 75% of tipping load with the machine on firm, level ground or 87% of full hydraulic capacity.
- The Lift-point is bucket pivot mounting pin on the arm (without bucket mass).
- (*) indicates load limited by hydraulic capacity.

LIFTING CAPACITY













 Lifting over-front
  Lifting over-side or 360 degree

HX360L

6.45 m (21' 2") boom, 2.5 m (8' 2") arm equipped with 600 mm (24") triple grouser shoe and 6,000kg (13,230 lb) counterweight.

Load point height m (ft)	Load radius										At max. reach								
	1.5m (4.9ft)		3.0m (9.8ft)		4.5m (14.8ft)		6.0m (19.7ft)		7.5m (24.6ft)		Capacity	Reach							
											kg (lb)	m (ft)							
7.5 m (24.6ft)											+8,820 +19,440	7,570 16,690	6.93 (22.7)						
6.0 m (19.7ft)											+9,310 +20,530	+9,310 +20,530	+8,740 +19,270	6,590 14,530	6,020 13,270	7.90 (25.9)			
4.5 m (14.8ft)											+13,730 +30,270	+13,730 +30,270	+10,630 +23,440	9,020 19,890	+9,230 +20,350	6,410 14,130	7,860 17,330	5,240 11,550	8.49 (27.9)
3.0 m (9.8ft)											+12,200 +26,900	+12,200 +26,900	8,520 18,780	9,360 20,640	6,180 13,620	7,330 16,160	4,860 10,710	8.79 (28.8)	
1.5 m (4.9ft)											12,800 28,220	8,130 17,920	9,130 20,130	5,960 13,140	7,190 15,850	4,740 10,450	8.82 (28.9)		
Ground Line											+15,200 +33,510	12,060 26,590	12,570 27,710	7,930 17,480	8,990 19,820	5,830 12,850	7,410 16,340	4,660 10,710	8.58 (28.2)
-1.5 m (-4.9ft)											+18,400 +40,570	12,120 26,720	12,530 27,620	7,890 17,390	8,970 19,780	5,820 12,830	8,110 17,680	5,300 11,680	6.06 (26.4)
-3.0 m (-9.8ft)											+21,480 +47,360	+21,480 +47,360	+16,690 +36,800	12,330 27,180	12,670 27,930	8,020 17,680	9,700 21,380	6,300 13,890	7.19 (23.6)
-4.5 m (-14.8ft)											+13,340 +29,410	12,750 28,110					+10,060 +22,180	8,800 19,400	5.80 (19.0)

6.45 m (21' 2") boom, 3.2 m (10' 6") arm equipped with 600 mm (24") triple grouser shoe and 6,000kg (13,230 lb) counterweight.

Load point height m (ft)	Load radius										At max. reach											
	1.5m (4.9ft)		3.0m (9.8ft)		4.5m (14.8ft)		6.0m (19.7ft)		7.5m (24.6ft)		9.0m (29.5ft)		Capacity	Reach								
													kg (lb)	m (ft)								
7.5 m (24.6ft)												+6,830 +15,060	6,770 14,930			+5,610 +12,370	+5,610 +12,370	7.74 (25.4)				
6.0 m (19.7ft)												+7,670 +17,350	6,710 14,790			+5,430 +11,970	5,270 11,620	8.62 (28.3)				
4.5 m (14.8ft)												+11,980 +26,410	+11,980 +26,410	+9,660 +21,300	9,210 20,300	+8,520 +18,780	6,500 14,330	+6,670 +14,700	4,820 10,630	+5,450 +12,020	4,660 10,270	9.17 (30.1)
3.0 m (9.8ft)												+15,550 +34,280	13,250 29,210	+11,360 +25,040	8,680 19,140	+9,400 +20,720	6,240 13,760	7,090 15,630	4,700 10,360	+5,650 +12,460	4,350 9,590	9.44 (31.0)
1.5 m (4.9ft)												+17,440 +38,450	12,390 27,320	+12,870 +28,370	8,220 18,120	9,160 20,190	5,990 13,210	6,960 15,340	4,580 10,100	+6,050 +13,340	4,240 9,350	9.47 (31.1)
Ground Line												+17,250 +38,030	12,040 26,540	12,590 27,760	7,940 17,500	8,970 19,780	5,810 12,810	6,870 15,150	4,500 9,920	6,600 14,550	4,320 9,520	9.25 (30.4)
-1.5 m (-4.9ft)												+10,800 +23,810	+10,800 +23,810	+18,950 +41,780	11,990 26,430	12,460 27,470	7,820 17,240	8,980 19,580	5,730 12,630	7,110 15,670	4,650 10,250	8.77 (28.8)
-3.0 m (-9.8ft)												+17,460 +38,490	+17,460 +38,490	+17,750 +39,130	12,120 26,720	12,510 27,580	7,870 17,350	8,940 19,710	5,790 12,760	8,210 18,100	5,350 11,790	7.98 (26.2)
-4.5 m (-14.8ft)												+20,680 +45,590	+20,680 +45,590	+15,250 +33,620	12,440 27,430	+11,460 +25,260	8,100 17,860			+9,640 +21,250	6,910 15,230	6.76 (22.2)

- Lifting capacity are based on ISO 10567.
- Lifting capacity of the Robex Series does not exceed 75% of tipping load with the machine on firm, level ground or 87% of full hydraulic capacity.
- The Lift-point is bucket pivot mounting pin on the arm (without bucket mass).
- (*) indicates load limited by hydraulic capacity.