



Operating Weight: 34300 kg Bucket Capacity: 1.5 - 2.0 m³ Engine Power: 256 HP (190.5 KW)/ 2000 rpm



**HIGH RELIABILITY
EXCELLENT PERFORMANCE
EASE OF SERVICEABILITY**



SANY HEAVY INDUSTRY INDIA PVT. LTD.

HEAD OFFICE
Address : Plot No. E-4, Chakan Industrial Area Phase-III,
Village Kuruli, Taluka Khed, District Pune - 410501,
Maharashtra, INDIA.
Tel : +91 21 35670288, Fax: +91 21 35670300
E-mail : customercare@sany.in
Website : www.sany.in
Toll Free No.: 1800-209-3337



Material & specification are subject to change without prior notice in accordance with our continuous technical innovations. Featured machines in photos may include additional equipment.

2018



**SERIES 9
SY350LC
HYDRAULIC EXCAVATOR**

The C-9 series of excavators developed by SANY adopts major breakthroughs ranging from power system to control system for high efficiency and energy savings. This, in addition to insistence on 'Quality-In-Everything-We-Do', has delivered the world-class excavators best suited for the multitude of your work requirements with superior advantages of uninterrupted operations, unmatched productivity at better fuel economy, helping you make more profits.

 **HIGH RELIABILITY**

Sany design and manufacturing capabilities have resulted into durability with improved life of components and longer service life.

 **EASE OF SERVICEABILITY**

With superior attention to details, smart provisions are made for easy serviceability and simplified maintenance that results into improved uptime.

 **EXCELLENT PERFORMANCE**

SY350LC-9H excavator is built with well renowned Isuzu engine and superior synchronization with advanced hydraulic system offering best balance of performance demands and fuel economy to suit job requirements and application.



REMOTE MONITORING SYSTEM

Remote monitoring system, called EVI, installed in the machines helps in tracking various working parameters. This information can be used for improving site efficiency, maximizing operating performance while reducing maintenance costs.

 **BEST IN CLASS OPERATOR COMFORT**

The machine is featured with comfortable seating arrangement, optimized cabin space, wider visibility, safety grills and easy access to switches. Overall, the new cabin provides comfortable and safe environment for the operator.





HIGH RELIABILITY

The boom and arm is made of large box-type structure welded with high strength steel sheet. Welded plates for excellent torsional resistance inside the structure leads to unmatched durability that prevents deformation under harsh conditions.

ROBUST STRUCTURE

REINFORCED BOOM

Robotically welded, heavy-duty boom is designed for best distribution of load throughout the boom structure which reduces lateral stress by 10% during the boom swing.

REINFORCED ARM

Arm's rear support is specially reinforced offering excellent torsional resistance imparting greater strength to the arm assembly for longer lifetime.

WEAR RESISTANT BUCKET

High strength bucket surface gives longer service life. Optimized design helps in reducing rock and sand resistance in turn decreases wear of the bucket body while digging.

HIGH STRENGTH UPPER FRAME

Heavy duty upper frame is designed to improve bending strength of the platform. D-shaped large section stronger beam can withstand external shocks.

ENHANCED UNDERCARRIAGE

Undercarriage is made up of high strength alloy steel with good wear resistance and durability.

X-TYPE FRAME AND BOX TYPE STRUCTURE

It has high strength and stiffness with excellent torsional and bending resistance. Reinforcing plate has been added to improve the strength of the lower frame. This improves working life.

STRENGTHENED TRACK

Anti-collision ribs have been added to improve its capacity of anti-deformation and protect the guide pulley.

Increased size of oil chamber of idler improve performance of floating seal results into effective life.

Strengthened undercarriage is featured with full length track guard for better protection in hardest possible application.

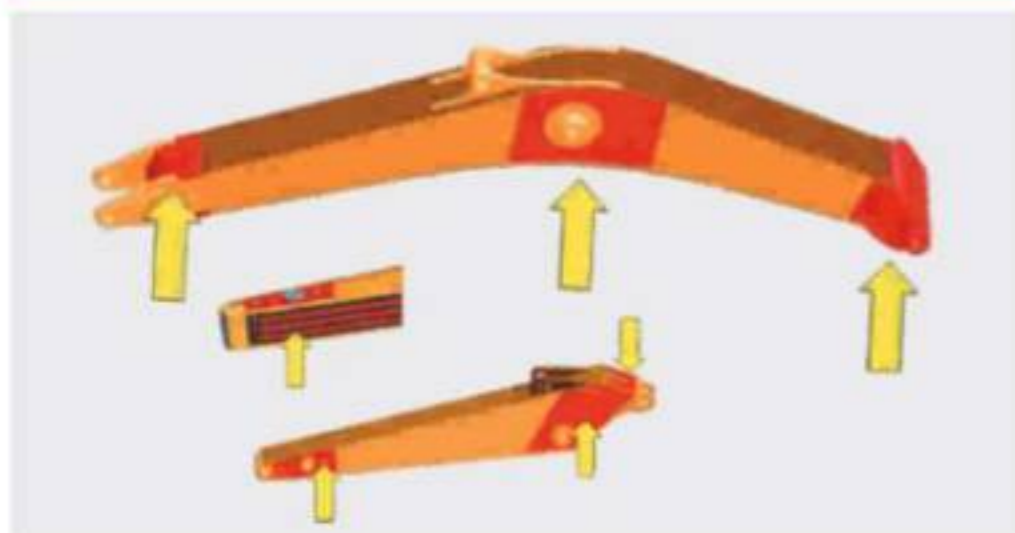

Boom & Arm



Bucket

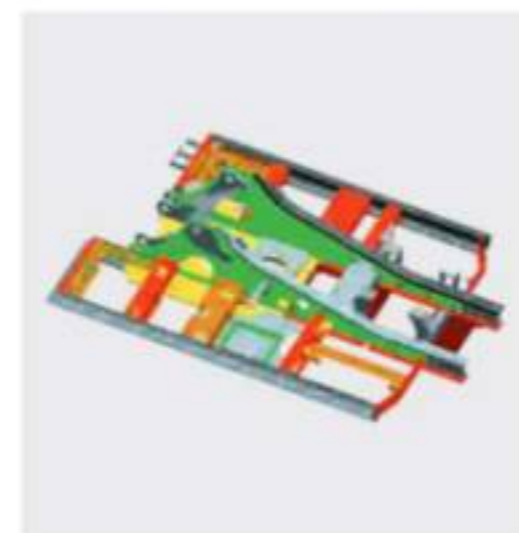

Upper Frame



X Type Frame

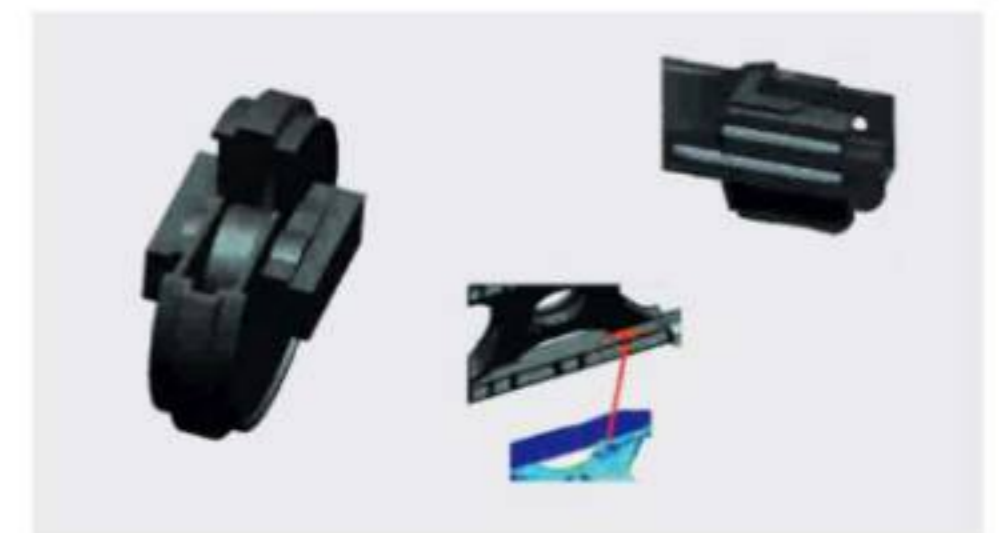

Idler & Reinforcement on X Frame

EXCELLENT PERFORMANCE

SANY SY350LC-9H excavator is designed for excellent performance with combination of best in class productivity and superior fuel economy.

HIGH PRODUCTIVITY

- POWERFUL ENGINE**
SY350LC-9H is powered by well renowned Isuzu engine with exceptional work capacity and optimize fuel economy for moving heavy material quickly and efficiently.
- ADVANCED HYDRAULIC SYSTEM**
When the machine deals with an operating requirement of moving heavy material quickly and efficiently, it needs the best hydraulic power that SY350LC-9H offers.
The advance control valve which has been thoroughly optimized provides excellent performance in combined operations.
Hydraulic valves ensure that oil flow is available at the point of priority as per required flow. This results in the best available power with optimum fuel consumption.
During boom lowering & arm opening operation, regeneration feature results into faster movement by routing oil through regeneration valve. It prevents cavitation and enhances cylinder performance. This reduces friction losses, pressure drops ensuring more power to the ground for heavy duty applications.



SUPERIOR FUEL EFFICIENCY

- DYNAMIC OPTIMIZATION MATCHING CONTROL SYSTEM (DOMCS)**
DOMCS ensures quick response to the change of operating variables in order to achieve optimum engine performance as per the external load demand facilitating the optimum control of excavator external load operation system.
- WORK MODES AND AUTO IDLE**
SY350LC-9H is equipped with four working modes (H, S, L, B) to match engine speed, pump speed and system pressure with versatile work application. Automatic idle function reduces fuel consumption significantly leading to reduced operating cost.

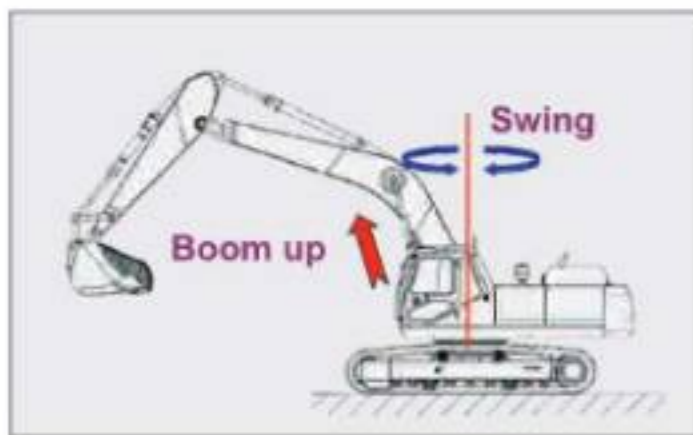

Boom Priority System

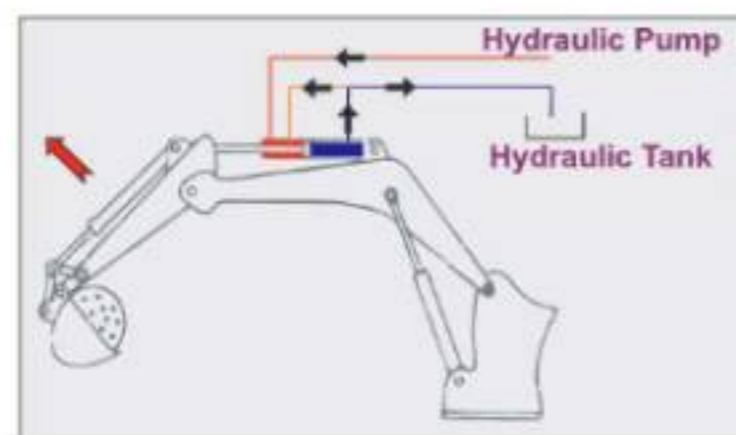

Regeneration System



Power Mode System

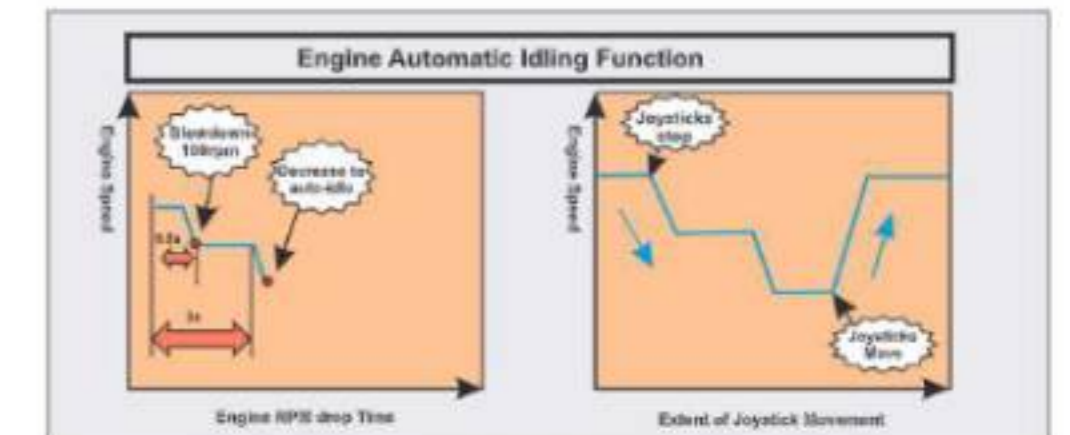

Auto Idle System



BEST IN CLASS OPERATOR COMFORT

Newly designed spacious air conditioned cabin is equipped with weight indication adjustable suspension. Height, backrest inclination, armrest height, rear cushioning of the seat is designed for operator comfort. This reduces operator fatigue and enhances working efficiency.

COMFORT

MULTI-DUCT AIR CONDITIONING SYSTEM

The standard large capacity air conditioner keeps in-cab air fresh by purification & recirculation which reduces operator fatigue.

ADVANCE SILICON RUBBER SHOCK ABSORBERS

Cabin bearing is attached to upper frame with silicone viscous shock absorber which effectively dampens vibrations while enhancing operator comfort.

PRESSURIZED HERMETIC CABIN

Cabin is air tight sealed and is dust free. It prevents dust entry into cabin gadgets by maintaining pressure variation between cabin and outside atmosphere.

ERGONOMICALLY DESIGNED JOYSTICK

Control levers and joysticks control are smartly designed for horizontal and vertical stroke of joystick for low lever effort.

HIGH STRENGTH ROOF TOP

The top plate of cabin is punch-formed with thick high-strength steel sheet integrated with reinforced ribs which offers excellent deformation-resistance resulting into operator safety in tough environments.

CLEAR VISIBILITY

Larger windows of the newly-designed spacious cabin provide you with a wider view. The operator can clearly see the work equipment condition and the surrounding through the front, side and back windows.

SAFETY HEAT SHIELD AND FAN COVER

Turbocharger and engine radiator are insulated with heat resistant cover. Engine radiator fan is fully enclosed with wire-mesh to reduce risk of accidents.

OTHER SAFETY PROVISIONS

Operator's cabin is equipped with safety hammer, fire extinguisher, seat belt, protective fence, hydraulic pilot lock.



AC Duct



Shock Absorber



Seat Adjustment



Joystick



Cabin Roof Top



Visibility



Fan Cover



Safety Hammer



EASE OF SERVICEABILITY

The use of OEM parts and quality elements effectively extends the service life and maintenance intervals. The time for maintenance is also reduced. Remote installation of replacement parts gives easy maintenance, higher utility and lower service cost.

EASY ACCESS

FILTER REPLACEMENT COMFORT

Access to the various filters (engine filter, pilot filter and A.C. filter) is very easy being mounted in hydraulic pump compartment for making cleaning easier.

EASY CLEANING FOR RADIATOR

Radiator and oil cooler packing is easily washable which leads into excellent cooling capacity and ensures prolonged engine running without being overheated.

DRAIN PLUG ARRANGEMENT

Radiator, fuel tank, hydraulic tank and engine oil pan are provided with drain-plug at the bottom to flush out the debris and waste liquids at the time of oil replacement and cleaning. The tank bottom has drain plug guard to prevent physical damage.

THREE-LEVEL FUEL FILTER

The fuel filter system is conveniently placed for easy access with three level filtration and additional strainer filter which removes contamination from fuel. This kind of filtration system prolongs engine life.

EASE OF REGULAR CHECK UP

Regular performing components (swing gear greasing, engine oil and hydraulic oil) of the machine can be easily checked up which leads to time saving and long working ability.

LARGE LCD COLOR DISPLAY

Cabin is equipped with waterproof, dust proof and vibration proof anti-interference colour LCD display which provides real-time information regarding machine working status, abnormal alarm function etc. ensuring safe operation.

IMPROVED GREASING

Graphite infused bushes are provided for prolonged greasing interval. Centralized greasing points are provided for easy greasing of various points of boom assembly.

FLOATING BUSH PROVISION

Floating bush and shim arrangement are provided in bucket for easy and quick adjustment.



Air Filter



AC Filter



Radiator



Drain Plug



Water Separator



Engine Oil Level Check-up Access



Color Monitor



Graphite Bush



Centralized Greasing Points



Floating Bush Provision



EVI REMOTE MONITORING

EVI in SANY C-9 series excavators is a sophisticated system that helps you to remotely monitor wide range of excavator functions and access operating information.

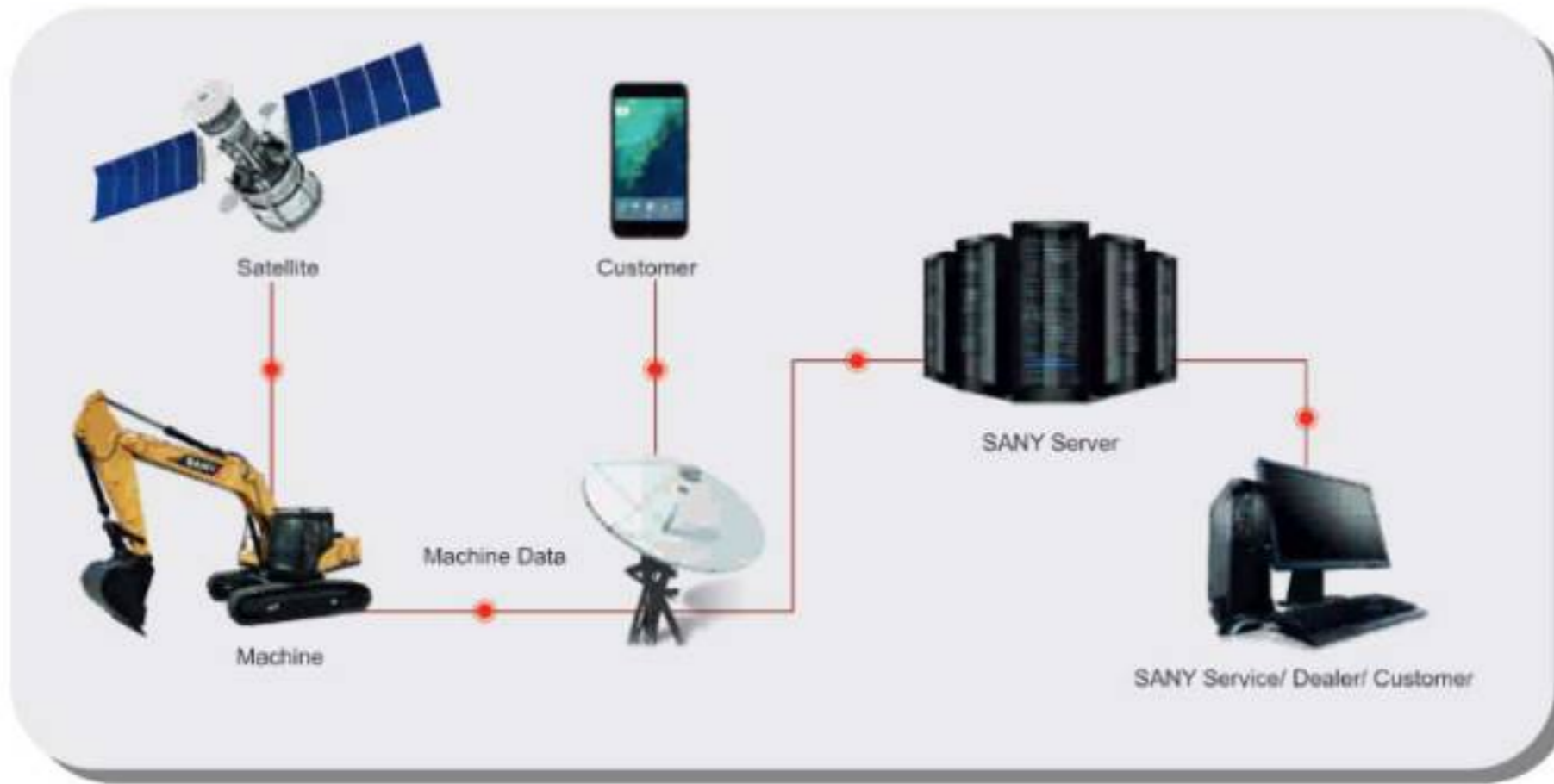

By 08-02-2011 09:43:58, the machine [1552-Y008105571] Total working hour is: 302.35 This time working hour is: 0.00 Longitude is: 0 Latitude is: 0 Gear position is: 0 Engine speed is: 0 Fuel level: 02.39222 [SanyEV]

By 08-02-2011 0:09:16:47, the machine [1552-Y008104671] Total working hour is: 395.45 This time working hour is: 0.00 Address: Kamakhyanagar Dhenkanal Road, Mahulpal, Odisha 759018, India. Gear position is: 0 Engine speed is: 22.4524 Fuel level: 0.302922 [SanyEV]

Daily SMS updates

1. Hour Meter Reading
2. Machine run on that particular day
3. Location of the machine
4. Engine speed & Gear Position
5. Fuel Level



MACHINE OPERATING MANAGEMENT

Daily machine operation hours, non-working hours, engine idling time can be monitored and remaining fuel in the diesel tank can be determined.



REAL-TIME MONITORING

The real-time monitoring system displays various operating parameters like hydraulic oil pressure, engine rpm, working mode along with selected gear, coolant temperature, voltages and current etc.



LOCATION & TRACKING

Machine's current location can be captured for easy tracking. Route to working site of the machine can be determined as well.

TECHNICAL SPECIFICATIONS

ENGINE	
Model	Isuzu AA-6HK1XQP
Type	6 Cylinder, In-line, Water Cooled
Rated Engine Power	256HP(190.5kW)/2000rpm
Max. Torque	872.8 N.m @ 1700 rpm
Batteries	2 X 12 V
Displacement	7.79 L

CONTROL SYSTEM	
Control System	DOMCS Intelligent Controller
Control Hydraulic System	Positive Flow
Working Modes	H, S, L, B
Remote Monitoring System	GPRS, GPS, GIS

HYDRAULIC SYSTEM	
Main Pumps	2 Variable Displacement Axial Piston Pumps
Max. Flow	2 X 316 lpm
Pilot Pump	1 Gear Pump
Travel Motor	2 Axial Piston Motor with Parking Brake
Swing Motor	1 Axial Piston Motor with Swing Holding Brake

RELIEF VALVE SETTINGS	
Implement Circuit	34.3 Mpa
Swing Circuit	26 Mpa
Travel Circuit	34.3 Mpa
Pilot Circuit	3.9 Mpa

UNDERCARRIAGE & WORKING DEVICE	
Track Shoes (Each Side)	49
Upper Rollers	2
Lower Rollers	9
Track Guard (Each Side)	2
Std. Track	600 mm
Std. Boom	6400 mm
Std. Arm	2400 mm
Std. Bucket	1.8 m ³ GP

PERFORMANCE	
Max. Travel Speed(High/Low)	5.2/3.4 km/h
Swing Speed	9.5 rpm
Grade ability	70% / 35
Ground Pressure	82 kPa
Max. Tracking Force	270 kN
Bucket Digging Force	233 kN
Arm Digging Force	212 kN

SERVICE REFILL CAPACITIES	
Hydraulic Tank	380 L (Tank)
Fuel Tank	540 L
Engine Oil	35 L
Radiator	31.9 L
Swing Device	10.5 L
Travel Device	2 X 5.0 L

CAB	
AC	Std.
Cabin Guard	Opt.

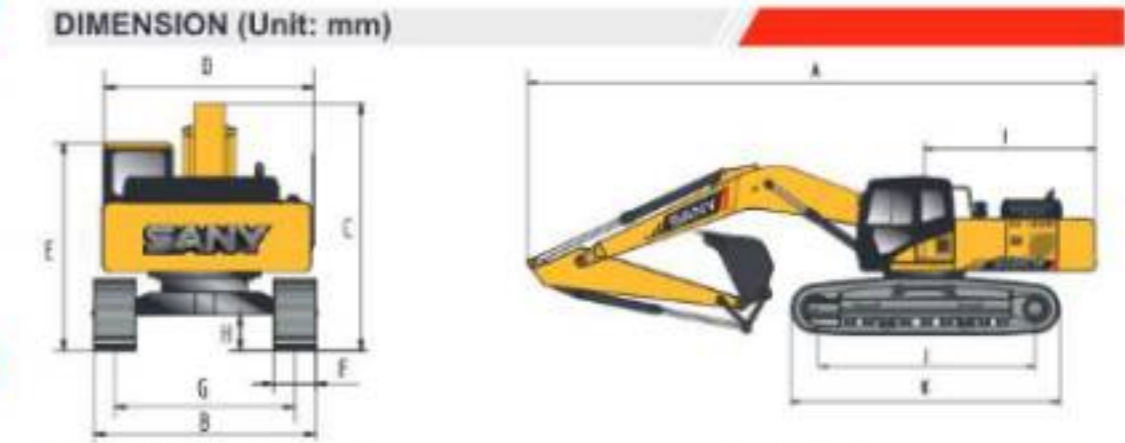

DIMENSION (Unit: mm)		Arm 2400
A. Overall Length		11200
B. Overall Width		3190
C. Overall Height		3810
D. Upper Width		3145
E. Overall Height of Cab		3085
F. Std. Track Shoe Width		600
G. Track Gauge		2590
H. Min. Ground Clearance		550
I. Rear-end Swing Radius		3300
J. Distance between Tumbles		4140
K. Under Carriage Length		5080

WORKING RANGE

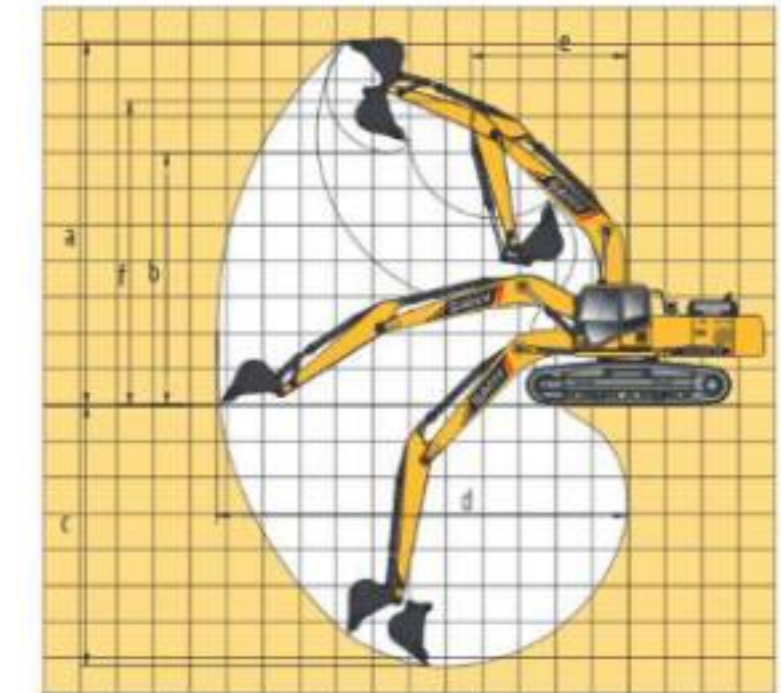

WORKING RANGE (Unit: mm)		Arm 2400
a. Max. Cutting Height		9848
b. Max. Dumping Height		7179
c. Max. Digging Depth		6541
d. Max. Digging Reach		10430
e. Min. Swing Radius		4329
f. Max. Height at Min. Swing Radius		8627

BUCKET		Capacity		Arm Length	
Capacity	Width (mm)	Weight (kg)	Tooth Point	2.4m	2.9m
1.5 m ³ HD-Opt.	1417	1321	5	✓	✓
1.8 m ³ GP-Std.	1668	1302	5	✓	✓
2.0 m ³ GP- Opt.	1720	1595	5	✓	-

LIFTING CAPACITY

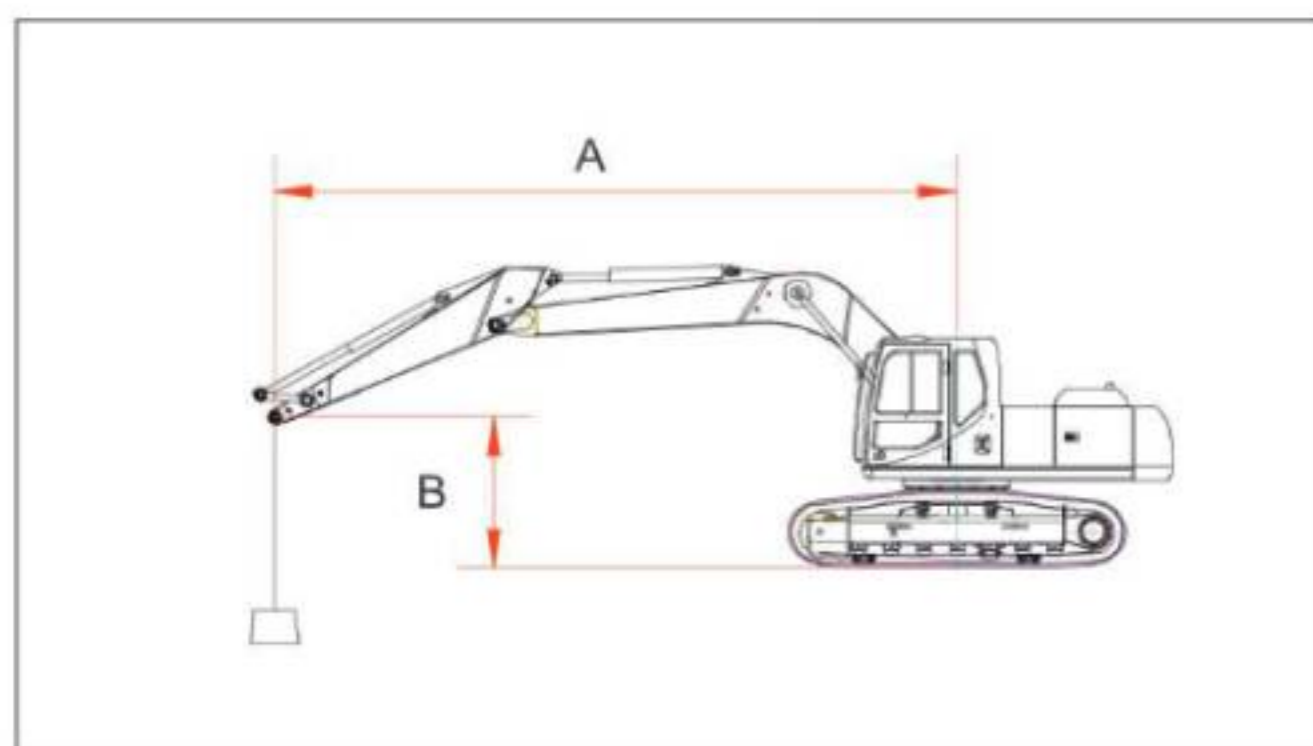

Boom 6400mm Arm 2400mm Shoe 600mm counterweight 6800kg

B \ A	3.0m		4.5m		6.0m		7.5m		9.0m		Maximum		
	🔧	⚙️	🔧	⚙️	🔧	⚙️	🔧	⚙️	🔧		⚙️	mm	
6.0m					*11046.88	8477.83	9745.38	5977.93			10063.64	6166.60	7360
4.5m			*15825.51	*12066.82	*12335.60	8041.71	9554.49	5812.90			8570.98	5239.81	8025
3.0m					13081.21	7545.92	9279.31	5575.01			7851.57	4766.14	8370
1.5m					12606.48	7155.57	9030.53	5359.94			7610.55	4581.24	8435
0					12354.77	6948.60	8875.21	5225.67			7786.08	4611.11	8230
-1.5m			*18145.72	10275.18	12307.04	6909.36	8853.16	5206.61			8492.53	5021.37	7730
-3.0m	*18689.33	*18689.33		10466.19	12450.69	7027.48					10183.32	5932.08	6870
-4.5m			*11631.10	10868.00							9662.76	8288.80	5485

Remarks:

1. Rated figure meets the criterion of GB/T 13331-2005/ISO 10576
2. Rated rollover loading is 75% of static rollover loading, rated limiting hydraulic weight is 87% of limiting hydraulic weight.
3. Loading radius is the distance from the loading point to the swing center.
4. The figure with *stands for the rated figure of the limiting hydraulic weight.

PRESSURE AND CAPACITIES

WEIGHTS AND GROUND PRESSURE

Shoe type	Shoe width	Model SY350LC-9H	
		Operating weight	Ground pressure
Triple grouser	600mm	34300Kg	51.7 Kpa

STANDARD EQUIPMENT

ENGINE

- Mode control (H, S, L and B) Start motor 24V/5.0KW
- Alternator 50A
- Air pre-cleaner
- Dry double-filtering air cleaner
- Cylindrical engine oil filter
- Cylindrical fuel filter
- Engine oil cooler
- Radiator with protective screen
- Auxiliary water tank for radiator
- Fan cowl
- Separately installed engine
- Automatic deceleration system
- Accelerating system

UNDERCARRIAGE

- Travel brake
- Travel motor guard
- H-track guiding mechanism
- Hydraulic track tensioner
- Bolted sprocket
- Carrier roller and track roller
- Reinforced track link with pin and seal
- 600 mm track shoes

SWING PLATFORM

- Fuel level float
- Hydraulic oil level gauge
- Toolbox
- Rear view mirror (R)
- Swing brake
- Reinforced side pedal
- Bottom cover plate

HYDRAULIC SYSTEM

- Working mode selection switch
- Power enhancement device
- Control valve with main relief valve
- Spare oil port for control valve
- Strainer
- Return oil filter
- Pilot filter

FRONT WORK EQUIPMENT

- Flange pin
- Bucket clearance adjustment
- Welded lever
- Central lubrication system
- Dust ring-seal of bucket pin
- Fully-welded box boom
- Fully-welded box arm
- Guard
- Standard bucket

ALARM LIGHTS

- Oil pressure alarm
- Engine coolant alarm
- Overheat alarm
- Fuel level alarm
- Voltage alarm
- Engine speed alarm

INDICATOR LIGHTS

- H working mode, S working mode
- L working mode
- Auto-idle, engine warm up
- Oil level, engine coolant temperature
- Travel speed

OPERATOR STATION

- Noise proof steel-structured cab
- Toughened light-color window
- 6 silicone rubber damping support
- Operable roof hatch, upper front window and left window
- Rear window, alternate exit
- Silent window wiper with washer
- Adjustable inclined seat with adjustable armrest
- AM-FM radio with digital clock
- Foot rest and floor mat
- Loudspeaker, rear view mirror
- Seat belt and fire extinguisher
- Cub holder and cab light
- Ashtray
- Storage box, literature bag
- Hydraulic lockout control
- Fully automatic air-conditioner
- Cab visor

OTHERS

- Standard battery
- Lockup engine hood
- Lockup fuel filler cap
- Anti-skid film, handhold and passage
- Travel direction mark
- Hand grease gun